

Design and Deployment of Optical Fiber Network at Atomic Energy Centre, Dhaka

Osman Goni

Designation: Engineer, Computer System and Network Division (CSND), Institute of Computer Science (ICS), Bangladesh Atomic Energy Commission, E-12/A, Agargaon, Sher-e-Bangla Nagar, Dhaka-1207, Bangladesh

Abstract: Fiber-optic communication is a method of transmitting information from one place to another by sending pulses of [infrared](#) light through an [optical fiber](#). The light is a form of [carrier wave](#) that is [modulated](#) to carry information. Fiber is [preferred over electrical cabling](#) when high [bandwidth](#), long distance, or immunity to [electromagnetic interference](#) is required. This type of communication can transmit voice, video, and telemetry through local area networks or across long distances. Optical fiber is used by many telecommunications companies to transmit telephone signals, Internet communication, and cable television signals. Researchers at [Bell Labs](#) have reached a record [bandwidth distance product](#) of over 100 [petabit](#) × kilometers per second using fiber optic communication. To fulfill the current requirements of Atomic Energy Center, Dhaka considering its smooth operation of high speed internet service, optical fiber based network is the state-of-the-art network solution. An optical fiber network design refers to the specialized processes leading to a successful installation and operation of a fiber optic network which includes determining the type of communication system(s) which will be carried over the network, the geographic layout, the transmission equipment required and the fiber network over which it will operate. Atomic Energy Centre, Dhaka (AECD), considered as the pioneer institution of the Bangladesh Atomic Energy Commission (BAEC) is now one of its research establishments located at the core of Dhaka city was established in 1961 to carry out research and development activities in the field of Nuclear science and technology for peaceful purposes. For that, here internet is essential. So optical fiber network design and deployment at Atomic Energy center is very important.

Keywords: Optical Fiber, Route Planning, Deployment, Network Design, BTCL, AECD, Frequency band, Wavelength.

Introduction

An optical fiber network provides high speed internet communication. The process of communicating using fiber-optics involves some basic steps such as creating the optical signal involving the use of a transmitter, relaying the signal along the fiber, ensuring that the signal does not become too distorted or weak, receiving the optical signal, and converting it into an electrical signal. An optical fiber based network can ensure high speed as well as high quality network.

To fulfill the current requirements of ICS (Institute of Computer Science) considering its smooth operation of high speed internet service, optical fiber based network is the state-of-the-art network solution. An optical fiber network design refers to the specialized processes leading to a successful installation and operation of a fiber optic network which includes determining the type of communication system(s) which will be carried over the network, the geographic layout, the transmission equipment required and the fiber network over which it will operate [1]. The design and deployment of optical fiber network was done carefully so that maximum performance could be attained. Optical fiber Communications technology is steadily our lives. Optical fibers which are being installed under the ground or overhead line but they are providing the means whereby enormous quantities of information of all kinds and for all types of use can now be made available to everyone worldwide this will change the way we work, play and generally live our lives. The technology of optical fiber Communication is developing rapidly[2]. In order that the development should be of maximum benefit to all in society, and should take place in directions controlled by society, it is necessary for the technology to be understood by a large cross- section of people. The nature and measure of information, the nature of light and the way in which it passes down receives of light signals and the optical amplifier, modulators, and switches that control the light. This involves a wide range of idea [3].The impact when Communication development for all of us. As with

all science and technology, the way of control it and to ensure that it is used for the benefit, rather than to the detriment of humankind is to understand it. Optical fiber Communication is set to become the dominant the communication technology of the twenty first century[4].

Atomic Energy Centre established in 1964 is the pioneer institution of the Bangladesh Atomic Energy Commission, located at the core of Dhaka city to carry out research and development activities in the field of Nuclear Science and Technology for peaceful use of atomic energy. The centre started functioning with major experimental facilities such as 3 MeV Van de Graft Accelerator, 5000 curies Cobalt- 60 source and 1620 IBM computer, the first digital computer of the country. Initially, the programs in the AECD focused on different fields of theoretical physics, experimental physics, radiobiology and nuclear medicine. After that, the centre has established collaboration research with other scientific institutions at home and abroad including relevant departments of different Universities of Bangladesh. The centre is providing training for human resource development and relevant R&D, and in academic fields of physical sciences to supports many universities leading to PhD, M.Phil, MS and B.Sc. degrees. The centre was the Precursor for a number of major research establishments of the country, namely, the Space Research and Remote Sensing Organization (SPARRSO) and Bangladesh Institute of Nuclear Agriculture (BINA) and Institute of Atomic Energy Research Establishment (AERE), Saver, Dhaka. At Present, R & D programs of AECD has been reorganized giving proper importance on the demands and needs of different national sectors of economy such as health, environment, trading, industry and agriculture. Many important baseline works on human health, environment, non-destructive testing and radiation protection were done in the AECD laboratories. Through these works, it has been possible to provide clinical differential diagnosis of Arsenic induced diseases in recent times in Bangladesh. One of the striking examples is the detection of high concentration of toxic particulate matter (PM) and lead in the air of Dhaka city, which drew attention of Government and the public and subsequently Government of Bangladesh undertook policy intervention like banning of leaded gasoline and two-stroke engine vehicles; promotion of using CNG instead of gasoline. Now, the R&D activities of AECD are conducted in 10 scientific divisions staffed by 60 qualified scientists and engineers. The total staff is about 210 including 83 technical persons [5].

2 Literature Review

2.1 Local Area Network

A local area network (LAN) is a [computer network](#) that interconnects computers within a limited area such as a residence, school, laboratory, university campus or office building [6] . By contrast, a [wide area network](#) (WAN) not only covers a larger geographic distance, but also generally involves [leased telecommunication circuits](#).



Figure.1: Local Area Network

2.2 Optical Fiber Cable

A fiber-optic cable, also known as an optical-fiber cable, is an assembly similar to an [electrical cable](#), but containing one or more [optical fibers](#) that are used to carry light. The optical fiber elements are typically individually coated with plastic layers and contained in a protective tube suitable for the environment where the cable is used. Different types of cable[7] are used for different applications, for example, long distance [telecommunication](#), or providing a high-speed data connection between different parts of a building [8].

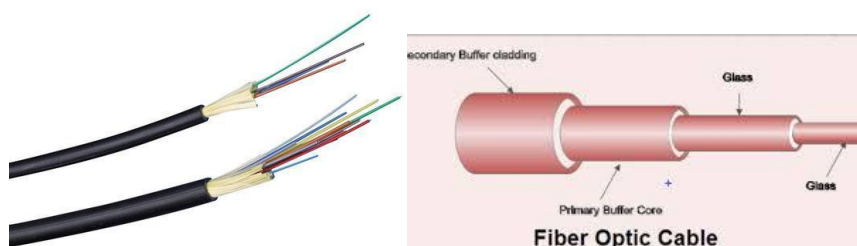

Figure.2: Optical Fiber Cable

2.3 Optical Fiber Communication Application

[Optical fiber](#) is used by telecommunications companies to transmit telephone signals, Internet communication and cable television signals. It is also used in other industries, including medical, defense, government, industrial and commercial. In addition to serving the purposes of telecommunications, it is used as light guides, for imaging tools, lasers, hydrophones for seismic waves, SONAR, and as sensors to measure pressure and temperature. The price for rolling out fiber to homes has currently become more cost-effective than that of rolling out a copper-based network. Prices have dropped to \$850 per subscriber in the US and lower in countries like The Netherlands, where digging costs are low and housing density is high[9]. In Bangladesh, Optical Fiber Communication occur mainly internet activities.

2.4 BTCL VERSUS AECD

BTCL or Bangladesh Telecommunications Company Limited is the largest telecommunications company in Bangladesh. The company was founded as the Bangladesh Telegraph & Telephone Board (BTTB) following Bangladesh's independence in 1971. On July 1, 2008 the BTTB became a public limited company and was renamed as BTCL[10]. BTCL works like ISP. AECD or Atomic Energy Centre is the oldest nuclear research Centre in Bangladesh and is located in [Dhaka, Bangladesh](#). It falls within the campus of University of Dhaka and is under the management of [Bangladesh Atomic Energy Commission](#)[11].

2.5 Bandwidth and Window of Fiber Optic Cable

In May 2002, the ITU-T organization divided the fiber optical communication system into six bands as O, E, S, C, L and U6. Multi-mode optical fiber at 850nm is known as the first window, single-mode optical fiber at O band is referred to as the second band. C band is called as the third window, L band is the forth window and E band is the fifth window. The following table shows the wavelength bands for both [multimode fiber optic cable](#) and single-mode fiber optic cable[12].

Table1: Fiber Optic Wavelength

Frequency band	Window	Wavelength range (nm)	Frequency range (THz)
/	1	850(770-910)	/
Original band	2	1260-1360	237.9-220.4
Extended band	5	1360-1460	220.4-205.3
Short wavelength band	/	1460-1530	205.3-195.9
Conventional band	3	1530-1565	195.9-191.6
Longer wavelength band	4	1565-1625	191.6-184.5
Ultralength wavelength band	/	1625-1675	184.5-179.0

The frequency range in the table above refers to the frequency of light. According to the formula, speed = wavelength x frequency, we can easily figure out the frequency of light. Its relation to the transmission loss of fiber optic cable and wavelength has been displayed as follow:

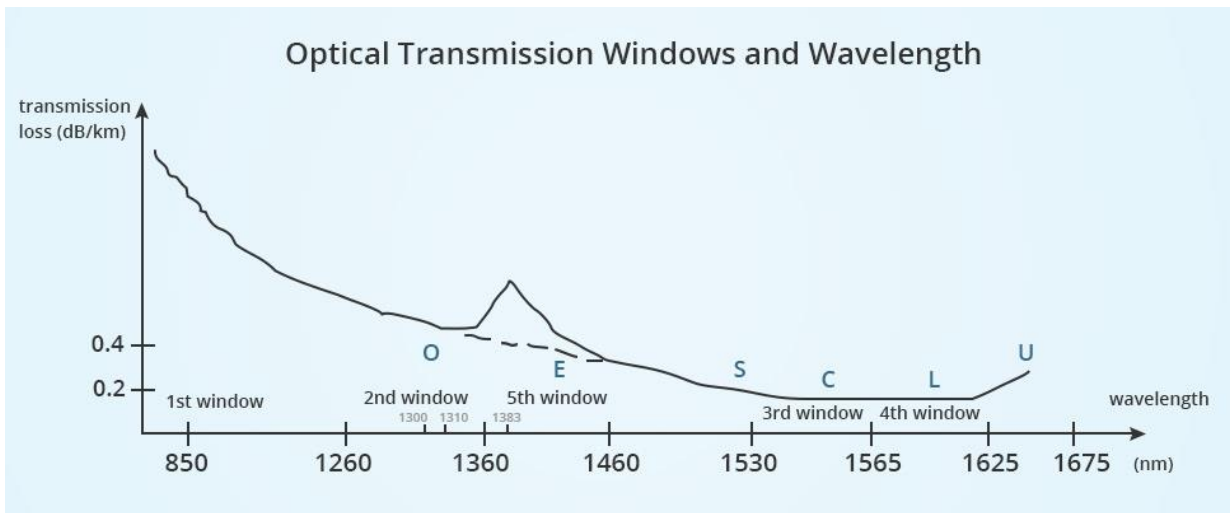

Figure.3: Optical Transmission Windows and wavelength

In the early days of fiber optic communication, the LED was employed as a light source due to its low price. Multi-mode fiber optic cables that operate at 850nm and 1300nm became the first choice for building small network, while single-mode optical fiber cables, working at 1310nm and 1550nm with laser as the light source were the foundation for constructing large network. If there were more windows available for single-mode optical cable, one fiber optic cable would achieve ultra-high speed transmission by transmitting signals at different wavelength at the same time by employing WDM (wavelength division multiplexing) technology, thus maximizing the potential of [single mode fiber](#). Telephone and network can be used at the same time via ADSL (asymmetric digital subscriber line) modem. That's because voice and data use different frequency. And this principle is similar with WDM and ADSL technology, which are usually applied in main networks that require higher bandwidth[13].

2.6 Optical Fiber Cable at OSI Model

The interface between an optical fiber and a twisted pair Cable can be at different layers of the OSI model. At the Physical layer a media converter can be used. It will transform the electrical Ethernet signal to Ethernet over fiber. At the data link layer, a layer 2 (Ethernet) switch can be used with copper and fiber interfaces. At the network layer a router can be used with an optical (fiber) interface and a copper (RJ45) interface. Conversion at the physical layer is a signal conversion. At the data link layer Ethernet packets will be switched or retransmitted at a different interface. At the network layer routing of IP packets to a different interface will take place.

3 Methodology

In my research paper, I have shown design and deployment of optical fiber cable from BTCL (Bangladesh Tele Communication Company Limited) to AECD (Atomic Energy Centre). BTCL works like greatest ISP Public Limited Company in Bangladesh. The Optical fiber cable comes from BTCL by underground. It must be need route planning. The route planning is BTCL Office to AECD office. In AECD, I Have configured all network devices (Firewall, Router, Server and Manageable switch). At final stage, I have setup all work station.

In my research paper, the methodology is following:

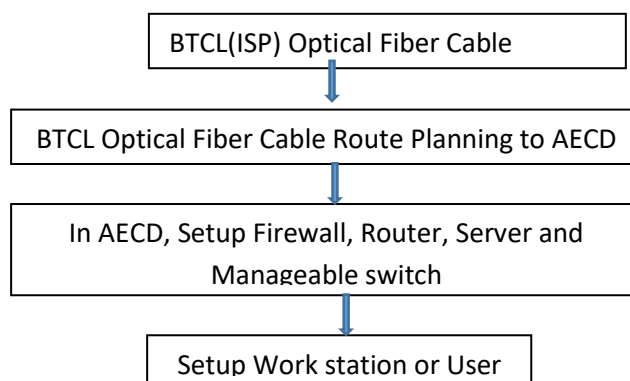

Fiber optical Communication is a method of transmitting information from one place to another by sending pulses of light through an optical fiber[14]. The light forms an electromagnetic carrier wave that is modulated to carry information.

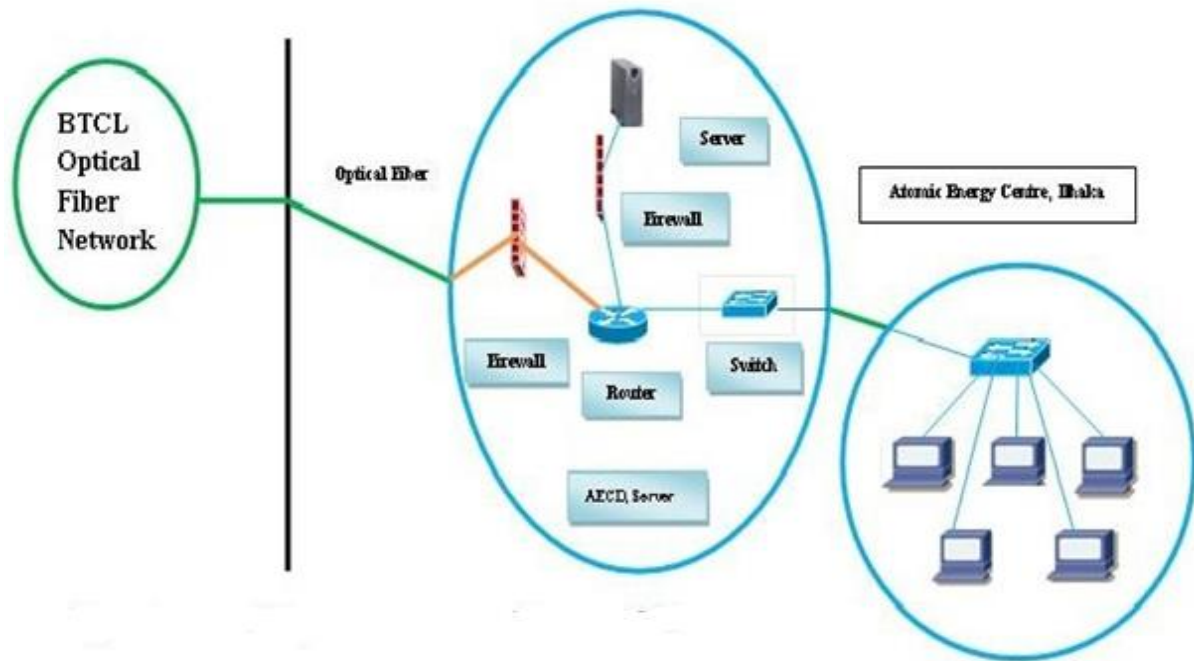

Figure.4: Diagram of Optical Fiber network at AECD

I consider actual component selection, placement, installation practices, testing, troubleshooting and network equipment installation and startup. Finally, I consider documentation, maintenance and planning for restoration in event of an outage. Existing local area network (LAN) consists of computer network that interconnects computers situated in different buildings at AECD using network media. Inside LAN, our employees are offered a computer network design applying metallic structured cabling CAT6. This cabling enables data transfer up to 100 Mbps. The network backbone is then customized using optical links. I perform dimensioning of active elements, such as switches and routers, to ensure their margin was sufficient to meet our data throughput rate requirements. I provide 10 Mbps internet bandwidth from BTCL for high speed broadband Internet Services.

Planning the route of optical fiber from BTCL to AECD to determine exactly where the cable plant and hardware will be located having decided to use fiber optics and chosen equipment appropriate for the application. As every installation is unique, the actual placement of the cable plant is determined by the physical locations from BTCL to AECD building along the route. The route distance is around 70 meter and I deploy the cable in the underground. Furthermore, as always premises and outside plant installations are different so we consider them separately. Finally planning for the deployment is a critical phase of any work as it involves coordinating activities of many people [15]. I develop a checklist based on the design path for smooth installation.

5 Result

Atomic Energy Centre (AECD) is a Scientific Organization and Bangladesh Tele Communication Company limited (BTCL) is a Land telephone and Greatest ISP Organization in Bangladesh. If I want to connect international network, I have to setup my Optical fiber network. For this in my paper, I have shown and practically configured Optical Fiber Network at Atomic Energy Centre, Dhaka My optical fiber network design and its deployment have been completed. As a result, this optical fiber network of Atomic Energy Centre, Dhaka (AECD) is getting a high speed internet service.

6 CONCLUSION

Optical fiber Communications technology is steadily our lives. Optical fibers which are being installed under the ground or overhead line but they are providing the means whereby enormous quantities of information of all kinds and for all types of use can now be made available to everyone worldwide this will change the way we work, play and generally live our lives. The technology of optical fiber Communication is developing rapidly [16]. In order that the development should be of maximum benefit to all in society, and should take place in directions controlled by society, it is necessary for the technology to be understood by a large cross-section of people. Optical fiber network is the smart network option for high-performance and it can provide cost-effective hybrid network architectures as well [17].

REFERENCES

- [1] T. F. O. Association, Guide To Fiber Optic Network Design, Wilshire Blvd: FOA Technical Bulletin, 2019.
- [2] H. J. R. Dutton, Understanding Optical Communication, Prentice Hall, 1999.
- [3] D. A. POUSTIE, Semiconductor Optical Amplifiers Light Up All-Optical Signal Processing, Ipswich, UK: Photonics Spectra, 2007.
- [4] A. H. M. U. S. O. T. M. M. Shafi, "Wireless communications in the twenty-first century: a perspective," IEEE, 10 October 1997. [Online]. Available: <https://ieeexplore.ieee.org/document/640770>. [Accessed 10 October 1997].
- [5] BAEC. [Online]. Available: www.baec.gov.bd.
- [6] G. A. Donahue, "Network Warrior," June 2007. [Online]. Available: https://en.wikipedia.org/wiki/Local_area_network. [Accessed June 2007].
- [7] M. Posinna, "different types of fiber optic cables," 1 april 2014. [Online]. Available: https://en.wikipedia.org/wiki/Fiber-optic_cable. [Accessed 1 april 2014].
- [8] H. Archived, 11 april 2016. [Online]. Available: https://en.wikipedia.org/wiki/Fiber-optic_cable. [Accessed 11 april 2016].
- [9] S. B. Edwin Conway, "Optical Fiber Communications Principles and Practice," 2019. [Online]. Available: https://en.wikipedia.org/wiki/Fiber-optic_communication.
- [10] T. N. Nation, ""BTTB, BSCCL turned into public limited company," 1 July 2008. [Online]. Available: <https://en.wikipedia.org/wiki/BTCL>. [Accessed 15 February 2010].
- [11] M. M. S. Haque, "en.banglapedia.org.," 15 Decmber 2017. [Online]. Available: https://en.wikipedia.org/wiki/Atomic_Energy_Centre,_Dhaka. [Accessed 15 December 2017].
- [12] Moris, "The Bandwidth and Window of Fiber Optic Cable," 18 September 2012. [Online]. Available: <https://community.fs.com/blog/the-bandwidth-and-window-of-fiber-optic-cable.html>.
- [13] Moris, "The Bandwidth and Window of Fiber Optic Cable," 18 September 2012. [Online]. Available: <https://community.fs.com/blog/the-bandwidth-and-window-of-fiber-optic-cable.html>.
- [14] R. Hui, Introduction to Fiber-Optic Communications, Kansas: Academic Press, 2019.
- [15] S. G. Michel Joindot, "Optical Fiber Transport Systems and Networks: Fundamentals," *Optical Fiber Transport Systems and Networks: Fundamentals*, pp. 1-21, 09 May 2019.
- [16] S. P. R. K. A. M. S. Prachi Sharma, "A Review of the Development in the Field of Fiber Optic Communication Systems," *International Journal of Emerging Technology and Advanced Engineering*, vol. 3, no. 5, 2013.
- [17] Tellabs, Why fiber Optical LANs are the better choice for high-performance green buildings, 1415 West Diehl Road: Tellabs Access, 2015.