

Monitoring and Controlling of an Air Quality for an Individual

Mr. M.Rajkumar B.E,M.Tech,(Ph.D) Associate Professor^{#1}, Sakthi.P^{#1}, Yuvashree.G^{#2}, Savitha.R^{#3}

^{#1#2#3}Student, Department of computer science and engineering
R.M.D Engineering College, R.S.M. nagar, kavaraipettai-601 206.
Affiliated to Anna University, Tamil Nadu, India.

Abstract

Nowadays, monitoring indoor air quality is critical because Americans spend 93% of their life indoors and around 6.3 million children suffer from asthma. We want to passively and unobtrusively monitor the asthma patient's environment to detect the presence of two asthma-exacerbating activities, smoking and cooking using the optical dust sensor, humidity sensor and temperature sensor. We propose a data-driven approach to develop a continuous monitoring-activity detection system aimed at understanding and improving indoor air quality in asthma management. Such a system will allow doctors and clinicians to correlate potential asthma symptoms and exacerbation reports from patients with environmental factors without having to personally be present. The data from the sensor can be transmitted to the cloud if we need.

1. Introduction

The use of automotive technology is to regulate indoor air quality through control of air conditioning and heating system. The proposed smart home management algorithm allows dynamic control of indoor ventilation system

2. Existing System

In existing system, they have developed a system, a framework for continuous monitoring of patient's personal, public, and population-based health signals that is designed to send alerts to the patient when an adverse condition is detected. This personal-level data includes questionnaires, individualized exhaled nitric oxide level, and indoor environmental measurements as well as activity level measured using fitness trackers.

Disadvantages

The main disadvantage is the cost inefficient. In existing system there is a need of costly sensors.

3. Proposed System

In this study, we focus on the personal level of the health framework. Specifically, we propose the use of the widely ubiquitous air quality monitor called humidity sensor, compact dust sensor and co2 sensor to monitor the patient's indoor environment. Three sensor measures five different

air quality parameters VOC, CO₂, Temperature (40 °Celsius), and Relative Humidity (60%) if any of the parameters value exceeds their thresholds

3.1 Advantages

- There has been no change in his outdoor environment, lifestyle or medications.
- Our research is the first step towards evaluating whether access to data related to patient's living surroundings can help doctors in continuous monitoring of the indoor air quality of their asthma patients and incorporate them with clinical records that contain information on an individual's asthma triggers, allergies, medications, and past emergency room visits for further insights on the role played by the indoor environment in asthma management
- The VOC reading of the sensor also accounts for carbon monoxide (CO), if present in the air. The sources of CO inside the house are cooking, conventional cigarette smoking or any kind of incomplete combustion

4. Block Diagram:

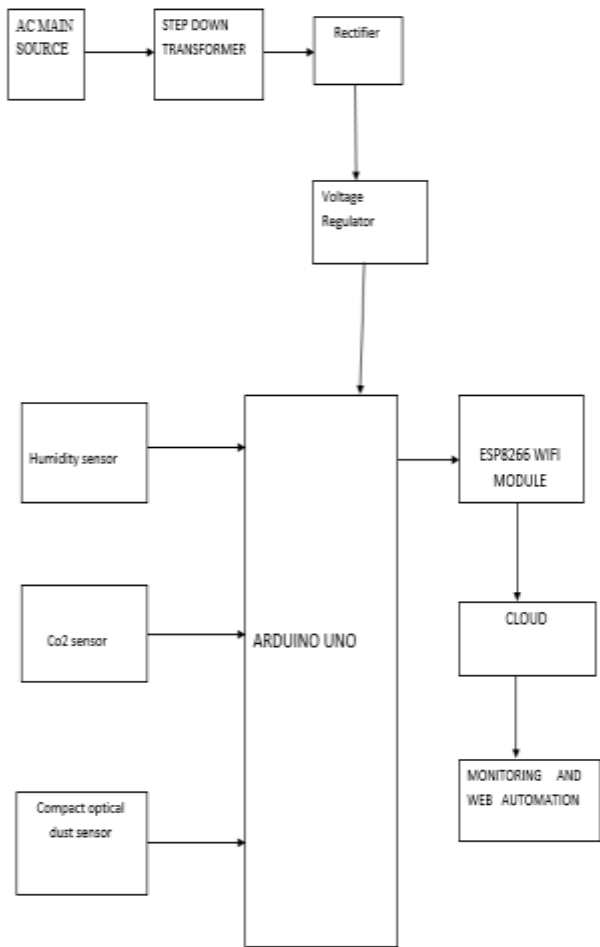

5. Types Of Sensors Used:

- Arduino
- Humidity sensor
- Temperature sensor

5.1.Arduino

Arduino is open source computer hardware and software company, project and user community that designs and manufactures microcontroller-based kits for building digital devices and interactive objects that can sense and control objects in the physical world.

The project is based on microcontroller board designs, manufactured by several vendors, using various microcontrollers. These systems provide sets of digital and analog I/O pins that can be interfaced to various expansion boards ("shields") and other circuits. The boards feature serial

communications interfaces, including USB on some models, for loading programs from personal computers. For programming the microcontrollers, the Arduino project provides an integrated development environment (IDE) based on the Processing project, which includes support for the C and C++ programming languages.

5.1.2. Arduino Microcontroller

Arduino is an open-source electronics prototyping platform based on flexible, easy-to-use hardware and software [2]. The Arduino microcontroller is essential to the design of the SRC as it provides communication between the voice recognition components and the graphical user interface (GUI). The 8bit data bus provides communication between the microprocessor and the HM2007. After Arduino microprocessor reads the 8bit data bus, the programmed microcontroller will decode and manipulated the 8bit signals. After processing the 8bit signals, the Arduino microcontroller sends the ASCII equivalent of the spoken word or phrase through a USB connection to the GUI. The GUI is written in the *Processing* language, which is based on Java. The details of the software used to program the Arduino microcontroller and the GUI will be discussed in later sections.

5.1.3. Software

The Arduino microcontroller is programmed with Arduino proprietary compiler. The compiler is based off of the C programming language. Included with the compiler is Arduino propriety libraries which allow the programmer to access to the external pins of the microcontroller. Arduino compiler has two reserved functions. These two functions are named `setup()` and `loop()`. The function, called `setup()`, is always executed when the Arduino microcontroller is initialized. The `loop()` function is continually evaluated while the Arduino microcontroller is running immediately after the `setup()` function.



5.1.4. Basic Algorithm

Within the setup() function, the eight pins on the microcontroller are established as inputs. This allows the eight pins to sense digital logic levels transmitted by the voice recognition components. This setup function also establishes the data rate at which the serial bus will be transmitted or received data. The serial bus is the communication link between the microcontroller and the graphical user interface. Therefore, any data written on to the serial bus by the microcontroller will be read by the graphical user interface, and vice versa. The loop() function will handle all the decoding of data from the voice recognition components and transmissions of data to the graphical user interface. This function will begin by reading the eight pins on the microcontroller. Since the value held on eight pins correspond to a specific phrase or word stored in the SRAM, the loop() function will decode that phrase or word into its ASCII value. That ASCII value will be transmitted to the graphical user interface over the serial bus. This methodically will be repeated continuously after the setup() function is executed. This is the basic algorithm of the Arduino microcontroller.

5.2. HUMIDITY SENSOR

Any external calibration or trimming to provide typical accuracies of $\pm \frac{1}{4} \text{ }^\circ\text{C}$ at room DHT11 digital temperature and humidity sensor is a composite sensor contains a calibrated digital signal output of the temperature and humidity. Application of a dedicated digital modules collection technology and the temperature and humidity sensing technology, to ensure that the product has high reliability and excellent long-term stability. The sensor includes a resistive sense of wet components and an NTC temperature measurement devices, and connected with a high-performance 8-bit microcontroller.

5.2.1. Applications

HVAC, dehumidifier, testing and inspection equipment, consumer goods, automotive, automatic control, data loggers, weather stations, home appliances, humidity regulator, medical and other humidity measurement and control.

5.2.2. Features

Low cost, long-term stability, relative humidity and temperature measurement, excellent quality, fast response, strong anti-interference ability, long distance signal transmission, digital signal output, and precise calibration.

5.2.3. Electrical characteristics

- Power supply: DC 3.5 ~ 5.5V
- Supply Current: measurement 0.3mA standby 60 μ A
- Sampling period: more than 2 seconds

5.2.4. Pin description

- VDD power supply 3.5 ~ 5.5V DC
- DATA serial data, a single bus
- NC, empty pin 4
- GND ground, the negative power

5.2.5. Typical circuit

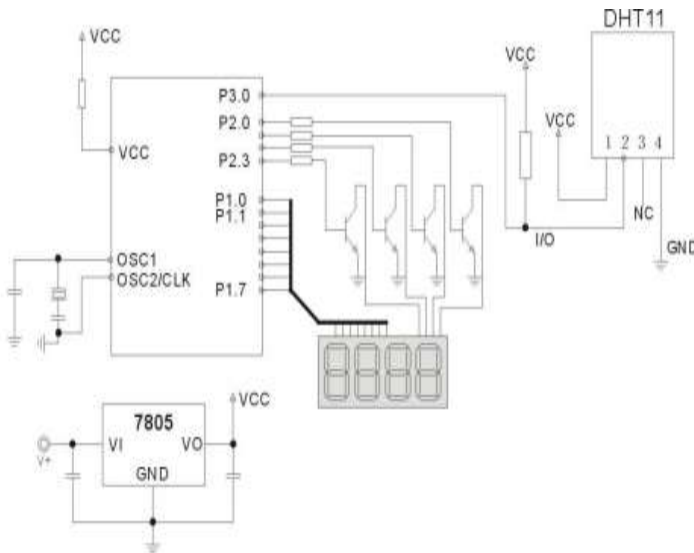

The LM35 is an integrated circuit sensor that can be used to measure temperature with an electrical output proportional to the temperature (in °C)

5.3.1.Features

- You can measure temperature more accurately than using a thermistor.
- The sensor circuitry is sealed and not subject to oxidation, etc.
- The LM35 generates a higher output voltage than thermocouples and may not require that the output voltage be amplified.

5.3.2. Overview

The LM35-series devices are precision integrated-circuit temperature sensors, with an output voltage linearly proportional to the Centigrade temperature. The LM35 device has an advantage over linear temperature sensors calibrated in Kelvin, as the user is not required to subtract a large constant voltage from the output to obtain convenient Centigrade scaling.

The LM35 device does not require temperature and $\pm \frac{3}{4}^{\circ}\text{C}$ over a full -55°C to 150°C temperature range. Lower cost is assured by trimming and calibration at the wafer level. The low output impedance, linear output, and precise inherent calibration of the LM35 device makes interfacing to readout or control circuitry especially easy. The device is used with single power supplies, or with plus and minus supplies. As the LM35 device draws only $60\ \mu\text{A}$ from the supply, it has very low self-heating of less than 0.1°C in still air. The LM35 device is rated to operate over a -55°C to 150°C temperature range, while the LM35C device is rated for a -40°C to 110°C range (-10° with improved accuracy). The temperature-sensing element is comprised of a delta-V BE architecture.

The temperature-sensing element is then buffered by an amplifier and provided to the VOUT pin. The amplifier has a simple class A output stage with typical $0.5\text{-}\Omega$ output impedance as shown in the Functional Block Diagram. Therefore the LM35 can only source current and its sinking capability is limited to $1\ \mu\text{A}$.

Functional Block Diagram (LM35)

Microprocessor and DHT11 of connection typical application circuit as shown above, DATA pull the microprocessor I / O ports are connected.

- Typical application circuit recommended in the short cable length of 20 meters on the 5.1K pull-up resistor, the resistance of greater than 20 meters under the pull-up resistor on the lower of the actual situation.
- When using a 3.5V voltage supply cable length shall not be greater than 20cm. Otherwise, the line voltage drop will cause the sensor power supply shortage, caused by measurement error.
- Each read out the temperature and humidity values are the results of the last measurement For real-time data, sequential read twice, but is not recommended to repeatedly read the sensors, each read sensor interval is greater than 5 seconds can be obtained accurate data

5.2.6.Technical details

- Low cost
- 3 to 5V power and I/O
- 2.5mA max current use during conversion (while requesting data)
- Good for 20-80% humidity readings with 5% accuracy
- Good for $0\text{-}50^{\circ}\text{C}$ temperature readings $\pm 2^{\circ}\text{C}$ accuracy
- No more than 1 Hz sampling rate (once every second)
- Body size $15.5\text{mm} \times 12\text{mm} \times 5.5\text{mm}$
- 4 pins with 0.1'' spacing

Temperature Sensor

- 2N2222 Transistor
- 1K Ohm Resistor
- Second Input Voltage Source

High current capacities, capability to stand ESD and drive circuit isolation are the unique properties of Relays.

6. Relay

A relay is an electrically operated switch. Many relays use an electromagnet to mechanically operate a switch, but other operating principles are used when it is necessary to control a circuit by a low-power signal or where several circuits must be controlled by one signal. The first relays were used in long distance telegraph circuits as amplifiers: they repeat the signal coming in from one circuit and retransmitted it on another circuit.

A type of relay that handle the high power required to directly control an electric motor or other loads is called a contactor. Solid state relays control power circuits with no moving parts, instead using a semiconductor device to perform switching.

A simple electromagnetic relay consists of a coil of wire wrapped around a soft iron core, an iron yoke which provides a low reluctance path for magnetic flux, a movable iron armature, and one or more sets of contacts. When an electric current is passed through the coil it generates a magnetic field that activates the armature, and the consequent movement of the movable contacts either makes or breaks a connection with a fixed contact.

Relay driver circuit

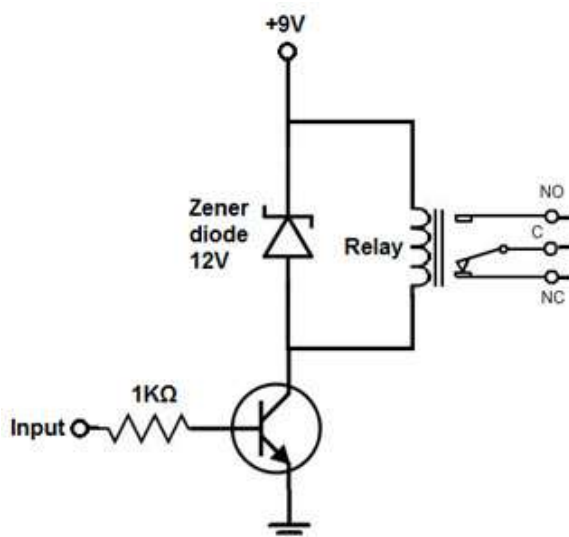

In order to drive the relay, we use transistor and only less power can be possibly used to get the relay driven. Since, transistor is an amplifier so the base lead receives sufficient current to make more current flow from Emitter of Transistor to Collector. The relay driver circuit as shown in above Fig.5.8.

The emitter-to-collector channel will be opened and allows current to flow through relay's coil if enough current or voltage is applied as input to the base lead. Driver Circuit is used to boost or amplify signals from micro-controllers to control power switches in semi-conductor devices. Driver circuits take functions that include isolating the control circuit and the power circuit, detecting malfunctions, storing and reporting failures to the control system, serving as a precaution against failure, analyzing sensor signals and creating auxiliary voltages.

Brushless Dc Motor

A DC motor is any motor within a class of electrical machines whereby direct current electrical power is converted into mechanical power. Most often, this type of motor relies on forces that magnetic fields produce. Regardless of the type, DC motors have some kind of internal mechanism, which is electronic or electromechanical. In both cases, the direction of current flow in part of the motor is changed periodically.

The speed of a DC motor is controlled using a variable supply voltage or by changing the strength of the current within its field wind rings. While smaller DC motors are commonly used in the making of appliances, tools, toys, and automobile mechanisms, such as electric car seats, larger DC motors are used in hoists, elevators, and electric vehicles.

A [12v DC motor](#) is small and inexpensive, yet powerful enough to be used for many applications. Because choosing the right DC motor for a specific application can be challenging, it is important to work with the right company. A prime example is MET Motors, which has been creating high-quality permanent magnet DC motors for more than 45 years.

Selecting the Right Motor

As part of the selection process for choosing the right DC motor, the professionals with MET Motors will first learn about your exact

application and then consider several different characteristics and specifications to ensure you end up with the best product possible.

One characteristic of a 12v DC motor is the operating voltage. When a motor is powered by batteries, low operating voltages are typically preferred since fewer cells are required to obtain the specified voltage. However, at higher voltages, electronics to drive a motor are typically more efficient. Although operation is possible with volts as low as 1.5 that goes up to 100, the most common are the 6v DC motor, 12v DC motor, and 24v DC motor.

Other key specifications of a 12v DC motor that MET Motors can assist with include the operating current, speed, torque, and power. Although a DC motor at this voltage is ideal for many applications, the company will consider everything prior to making the final recommendation.

8.2. Features

- Long-life: Intermittent operation over 1 million cycles with optimized brush design*1
- Continuous operating life of 3000 hours*1
- High output: High heat dissipation and heat resistance achieves higher output
- High strength: High radial load capacity due to robust construction, large diameter output shaft and ball bearings.

ZIGBEE

ZigBee is a wireless networking standard that is aimed at remote control and sensor applications which is suitable for operation in harsh radio environments and in isolated locations.

ZigBee technology builds on IEEE standard 802.15.4 which defines the physical and MAC layers. Above this, ZigBee defines the application and security layer specifications enabling interoperability between products from different manufacturers. In this way ZigBee is a superset of the 802.15.4 specification.

With the applications for remote wireless sensing and control growing rapidly it is estimated that the

market size could reach hundreds of millions of dollars as early as 2007. This makes ZigBee technology a very attractive proposition for many applications.

ZigBee basics

The distances that can be achieved transmitting from one station to the next extend up to about 70 meters, although very much greater distances may be reached by relaying data from one node to the next in a network.

The main applications for 802.15.4 are aimed at control and monitoring applications where relatively low levels of data throughput are needed, and with the possibility of remote, battery powered sensors, low power consumption is a key requirement. Sensors, lighting controls, security and many more applications are all candidates for the new technology.

Interface XBee Module with PIC Microcontroller

Zigbee module is connected with usart tx or rx pin ,from that we can send data or receive data

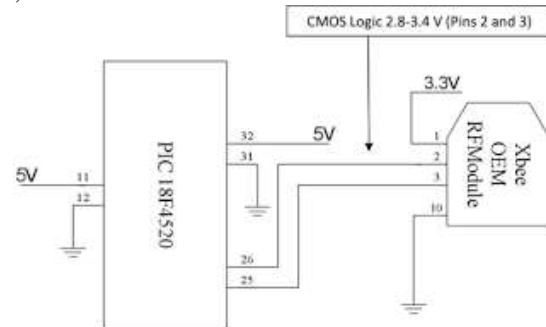

Figure 4: Circuit Schematic PIC to Xbee

ZigBee is a specification for a suite of high level communication protocols using small, low-power digital radios based on the IEEE 802.15.4-2003 standard for wireless personal area networks (WPANs) ZigBee is a low data rate, two-way standard for industrial and domestic automation networks. • It uses small very low-power devices to connect together to form a wireless control web. The standard supports 2.4GHz unlicensed radio bands. • Popular name for the IEEE 802.15.4 standard for an extremely low power, and low bit rate wireless PAN technology, Zigbee is designed for wireless automation and other lower data tasks, such as smart home automation and remote monitoring.

9.4. Data Transfer

The data is transferred in packets. These have a maximum size of 128 bytes, allowing for a maximum payload of 104 bytes. Although this

may appear low when compared to other systems, the applications in which 802.15.4 and ZigBee are likely to be used should not require very high data rates.

The standard supports 64bit IEEE addresses as well as 16 bit short addresses. The 64 bit addresses uniquely identify every device in the same way that devices have a unique IP address. Once a network is set up, the short addresses can be used and this enables over 65000 nodes to be supported.

It also has an optional super frame structure with a method for time synchronization. In addition to this it is recognized that some messages need to be given a high priority. To achieve this, a guaranteed time slot mechanism has been incorporated into the specification. This enables these high priority messages to be sent across the network as swiftly as possible.

9.5. Upper layers (ZigBee)

Above the physical and MAC layers defined by 802.15.4, the ZigBee standard itself defines the upper layers of the system. This includes many aspects including the messaging, the configurations that can be used, along with security aspects and the application profile layers.

There are three different network topologies that are supported by ZigBee, namely the star, mesh and cluster tree or hybrid networks. Each has its own advantages and can be used to advantage in different situations.

The star network is commonly used, having the advantage of simplicity. As the name suggests it is formed in a star configuration with outlying nodes communicating with a central node.

Mesh or peer to peer networks enable high degrees of reliability to be obtained. They consist of a variety of nodes placed as needed, and nodes within range being able to communicate with each other to form a mesh. Messages may be routed across the network using the different stations as relays. There is usually a choice of routes that can be used and this makes the network very robust. If interference is present on one section of a network, then another can be used instead.

Finally, there is what is known as a cluster tree network. This is essentially a combination of star and mesh topologies.

Both 802.15.4 and ZigBee have been optimized to ensure that low power consumption is a key feature. Although nodes with sensors of control mechanisms towards the center of a network are more likely to have mains power, many towards the extreme may not. The low power design has enabled battery life to be typically measured in years, enabling the network not to require constant maintenance.

Although there is an increasing number of wireless standards that are appearing, ZigBee has a distinct area upon which it is focused. It is not intended to compete with standards such as 802.11, Bluetooth and the like. Instead it has been optimized to ensure that it meets its intended requirements, fulfilling the needs for remote control and sensing applications.

Applications

- 2400-2483.5 MHz ISM/SRD band systems
- Consumer electronics
- Wireless game controllers
- Wireless audio
- Wireless keyboard and mouse
- RF enabled remote controls

Conclusion:

Thus, to facilitate the asthma patient and to preserve room environment, we use the technique of monitoring and controlling of an air quality for an individual.

References

- [1] R. Mao and H. Li, "Nobody but you: Sensor selection for voltage regulation in smart grid," arXiv preprint arXiv:1103.5441, 2011.
- [2] H. Liang and W. Zhuang, "Stochastic modeling and optimization in a microgrid: A survey," *Energies*, vol. 7, no. 4, pp. 2027–2050, 2014.
- [3] H. Liang, A. Abdrabou, and W. Zhuang, "Stochastic information management for voltage regulation in smart distribution systems," in *Proc. of the INFOCOM. IEEE*, 2014, pp. 2652–2660.
- [4] X. Wang and Q. Liang, "Stabilizing the power supply in microgrid using sensor selection," in *Proc. of the of the Global Communications Conference*, 2012, pp. 3513–3518.

- [5] N. Kayastha, D. Niyato, E. Hossain, and Z. Han, "Smart grid sensor data collection, communication, and networking: A tutorial," *Wireless Communications and Mobile Computing*, 2012