

Design and Implementation of UPFC Using Ten Switch Converter With Switch Reduction

D.Aarthi, R.Manivasagam

PG Scholar , K.Ramakrishnan College Of Engineering,
Samayapuram-Trichy,Tamilnadu,India.

email.id:aarthivasan83@gmail.com

Assistant Professor / EEE , K.Ramakrishnan College Of
Engineering,Samayapuram-Trichy,Tamilnadu,India.

email.id:manivasagammn3@gmail.com.

Abstract

Unified Power Flow Controller (UPFC) be one of the most comprehensive FACTS devices which can controls three system parameters independently. In this system a novel configuration of UPFC which consists of a ten switch converter parallel with a series. Capacitor has been proposed to inject desired series voltage. It means that operation of ten-switch converter in this configuration be the same as combination of two converters in conventional UPFC. However, proposed configuration requirements less power electronics switches and gate drive circuits and control scheme becomes simpler than conventional UPFC configuration, using series capacitor parallel by ten switch converter reduce the injection voltage's THD, eliminate output filter, also decrease the converters power rating in comparison with conventional UPFC composed of series and shunt converters. The proposed UPFC is modeled using MATLAB/SIMULINK software and simulation results are presented to indicate good operation of the new UPFC.

Keywords: UPFC(Unified Power Flow Controller, THD(Total Harmonic Distortion), FACTS(Flexible AC Transmission Systems), VSI(Voltage Source Inverter), PWM(Pulse Width Modulation).

1.Introduction

Today with the progress of power electronic, Flexible AC transmission systems (FACTS) are one of the most important technologies which is expanding more than other electric power control strategies. FACTS devices

can control the power flow in transmission line, regulate voltage at the point connection to network and compensate reactive power. Also FACTS devices can utilize in power system damping enhancement because they have acceptable time response to damp oscillations. As mentioned advantages the uses of FACTS are increasing of voltage regulation, power transferring capability, and damping of power oscillations. Most comprehensive device in the FACTS concept is the unified power flow controller (UPFC). It can adjust the three control

parameters of system simultaneously and independently.

The transmission line reactance, bus voltage, and phase angle between two buses are parameters can be control using UPFC. The conventional UPFC is composed of two voltage source converters, one of them is connected in series with power system network with other in shunt and both are connected back to back during a DC link.

Due to the conventional UPFC is based on using two 2-level-3-phase voltage source converters, it cause problem which the injected series voltage is not a sinusoidal waveform with low THD and output filters are essential. UPFC based “zigzag transformer links” through “multilevel converters” be two option to clarify this problem which reported.

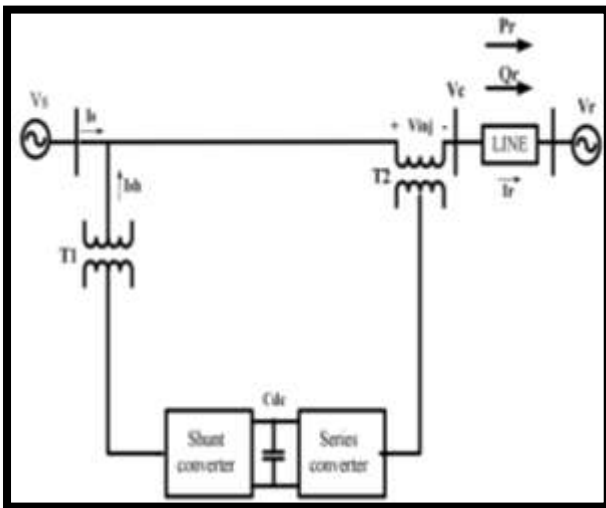

Figure 1. Conventional UPFC consist of shunt and series converters

Zigzag arrangement solve THD problem but increase the cost, volume, power loses and also control of this structure is difficult. On the other

hand, multilevel converters require complex circuit and control strategy to satisfy THD standards. To overcome mentioned problems, recently proposes a novel topology of UPFC which is consists of two 3-phase back-to-back shunt converters and a series capacitor. In this topology the cost, volume and rated power of UPFC is decreased. Also both of converters are connected in parallel with line so the control scheme becomes simpler than conventional UPFC, and more important than aforementioned advantages of this configuration is reduction of injected voltage THD. In this topology 2-level 3-phase back-to-back converter has been used, so it requires twelve power electronic switches. Recently the novel ten-switch converter has been introduced as a good alternative to existing 3-phase back-to-back converters as shown in Figure 1. In comparison with back-to-back converters, the proposed ten-switch converter uses fewer number of power electronic switches which reduces the cost.

This system present a novel UPFC based on two parallel connections and a series capacitor. In proposed UPFC the novel ten-switch converter has been used instead of back-to-back converter so the number of power electronic switches reduced from twelve to ten in comparison with reported topology.

In this system first a new ten-switch converter is introduced and the carrier based PWM switching algorithm for this converter has been considered. Novel UPFC based on ten-switch converter is explained in next section.

Simulation results on proposed UPFC are provided to confirm operation of proposed structure.

2. Ten Switch Converter

This system proposes a new reduced switch UPFC system topology that comprises of ten switches in total. The main purpose is to decrease the overall switch count of the back-to back UPFC system while retaining its operational features without any performance transaction. To retain the linear modulation range and uniform switching frequency for all the switches within the proposed topology, a carrier based binary zero sequence injection scheme is also developed. An appropriate control algorithm is developed to accomplish the seamless process of the proposed UPFC topology under different operating conditions. An experimental study is voted for out to authenticate the performance of the proposed topology.

In this system, a novel topology of UPQC, based on ten switches, is proposed for power quality enhancement applications. The proposed topology is realized by combining the phase C switches of shunt and series VSI in Figure. 1, respectively, into a common leg with a shared set of two switches. Until now the ten-switch structure has been utilized in drives applications with certain limitations.

TABLE 1: Switching States For Phase ‘‘C’’ Of Shunt And Series VSI In Existing System

Voltage	Switching State
$V_{sh} = V_{sr} = V_{dc}$	$S_{C1}, S_{C'1} = \text{ON}$ and $S_{C2}, S_{C'2} = \text{OFF}$
$V_{sh} = V_{sr} = 0$	$S_{C2}, S_{C'2} = \text{ON}$ and $S_{C1}, S_{C'1} = \text{OFF}$
$V_{sh} = V_{dc}$ and $V_{sr} = 0$	$S_{C1}, S_{C'2} = \text{ON}$ and $S_{C2}, S_{C'1} = \text{OFF}$
$V_{sh} = 0$ and $V_{sr} = V_{dc}$	$S_{C2}, S_{C'1} = \text{ON}$ and $S_{C1}, S_{C'2} = \text{OFF}$

TABLE 2: Switching States For Phase ‘‘C’’ Of Shunt And Series VSI In Ten-Switch Configuration

Voltage	Switching State
$V_{sh} = V_{sr} = V_{dc}$	$S_{C1} = \text{ON}$ and $S_{C2} = \text{OFF}$
$V_{sh} = V_{sr} = 0$	$S_{C1} = \text{OFF}$ and $S_{C2} = \text{ON}$
$V_{sh} = V_{dc}$ and $V_{sr} = 0$	Not Realizable
$V_{sh} = 0$ and $V_{sr} = V_{dc}$	Not Realizable

Ten-switch configuration was earlier to replace twelve-switch back-to-back converter for dual induction machine drive system. even though the configuration allows independent control of both machines with a wide range of variation in load torque and rotational speeds, it imposes a drawback on the dc link voltage. If U_{m1} and U_{m2} are the maximum values of phase-to-phase voltages at the terminal of the induction machine M1 and M2, respectively,

$V_{DC} \geq \max(U_{m1} + U_{m2})$ for ten-switching system

$V_{DC} \geq \max(U_{m1}, U_{m2})$ for twelve – switching system

Where V_{dc} is the voltage across the dc link capacitor. In the special case of $u_{m1}=u_{m2}= U$ the following constraints can be established.

$V_{DC} \geq 2U$ for ten – switch system

$V_{DC} \geq U$ for twelve – switch system

Equation implies that the dc link voltage must be doubled to achieve the maximum rotational speed for both machines at the same time. Doubling of dc link voltage increase all the component stress by two folds, thus, offsetting the saving of two switches. For the equivalent dc link voltage, the ten-switch structure leads to reduction in the terminal voltage and subsequent speed range of both equipment. Attempts to enhance the dc-bus utilization for the ten-switch architecture have been reported. The improvement reported, is obtained at the expense of identical operating (speeding and loading) conditions for both machines. The controller divides the dc link voltage through allocate predefined switching vectors near each machine. The restriction that the regulator must have prior knowledge of the voltage profile for each machine make the system impractical for variable industrial loads. The ten-switch configuration is employed to drive the two induction motors in the midpoint driven winders. It overcomes the limitation of dc link over sizing given by due to ‘inverse load outline’ of the two equipment. When one motor start at maximum speed, the other motor operates at minimum speed and vice versa. because both motors

increase/decrease velocity in an exchange fashion, their voltage requirement is absolutely different (opposite). This allows the ten-switch scheme to continue operational for middle driven winders utilizing the same dc link voltage required for end-to-end converter. However, the center driven winder is a special case and in general ten switch configurations have not shown much economic value for dual motor drive systems.

3. Proposed System

A traditional UPFC to control active and reactive power flow transmission simultaneously is composed of series and shunt converters which are connected back-to-back with common dc-link capacitor as shown in Figure. The voltage of the UPFC bus or its reactive power is controlled by the shunt converter and it also regulates the dc link voltage. The series converter is controlled by the transmission line active and reactive power flow by injecting a desired series voltage, which is controllable equally in magnitude and phase angle. The series converter injects voltage to transmission line, by changing injected series voltage active and reactive power exchange between the series converter and the power system. Active power required by the series converter plus the losses of the UPFC converters has been provided by the shunt converter.

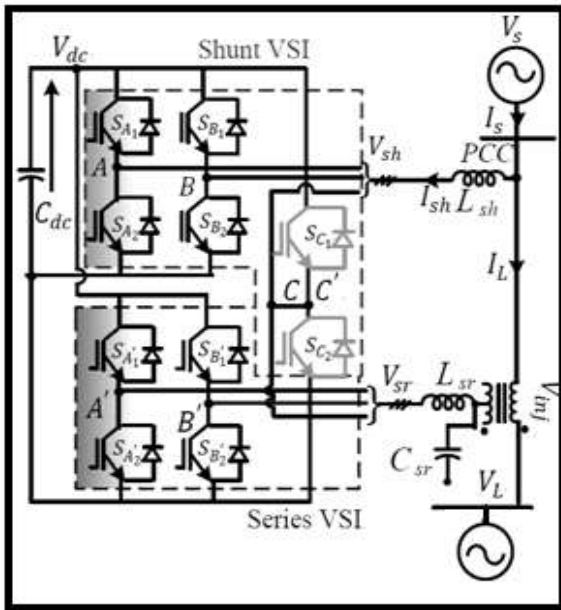

Figure 2: Proposed ten-switch UPFC.

A series capacitor has been used in parallel between two shunt converters which desired injection voltage to control active and reactive power has been injected by this capacitor, using this configuration reduce THD, eliminate output passive filter, and also reduce converters power rating compared with the conventional UPFC

consist of series and shunt converters. In proposed UPFC in this paper, a ten-switch ac-ac converter has been used instead two dc-ac converters in novel UPFC based on two shunt converters and a series capacitor. like mentioned in this converter, the input and output voltages can be independently controlled then it can be noted that the operation of ten-switch ac/ac converter in this configuration is the same as combination of two dc/ac converters in conventional configurations.

4.Experimental Results And Discussions

To approve the execution of the proposed ten-switch UPFC, an exploratory model is created. The results and experimental study is given roar. The arrangement part adequately mitigates the sounds in the framework voltage. The enhanced load voltage profile can be taken wherein the THD is lessened to 3%. All the while, the shunt controller viably adjusts the heap

Existing Twelve Switch Circuit Block

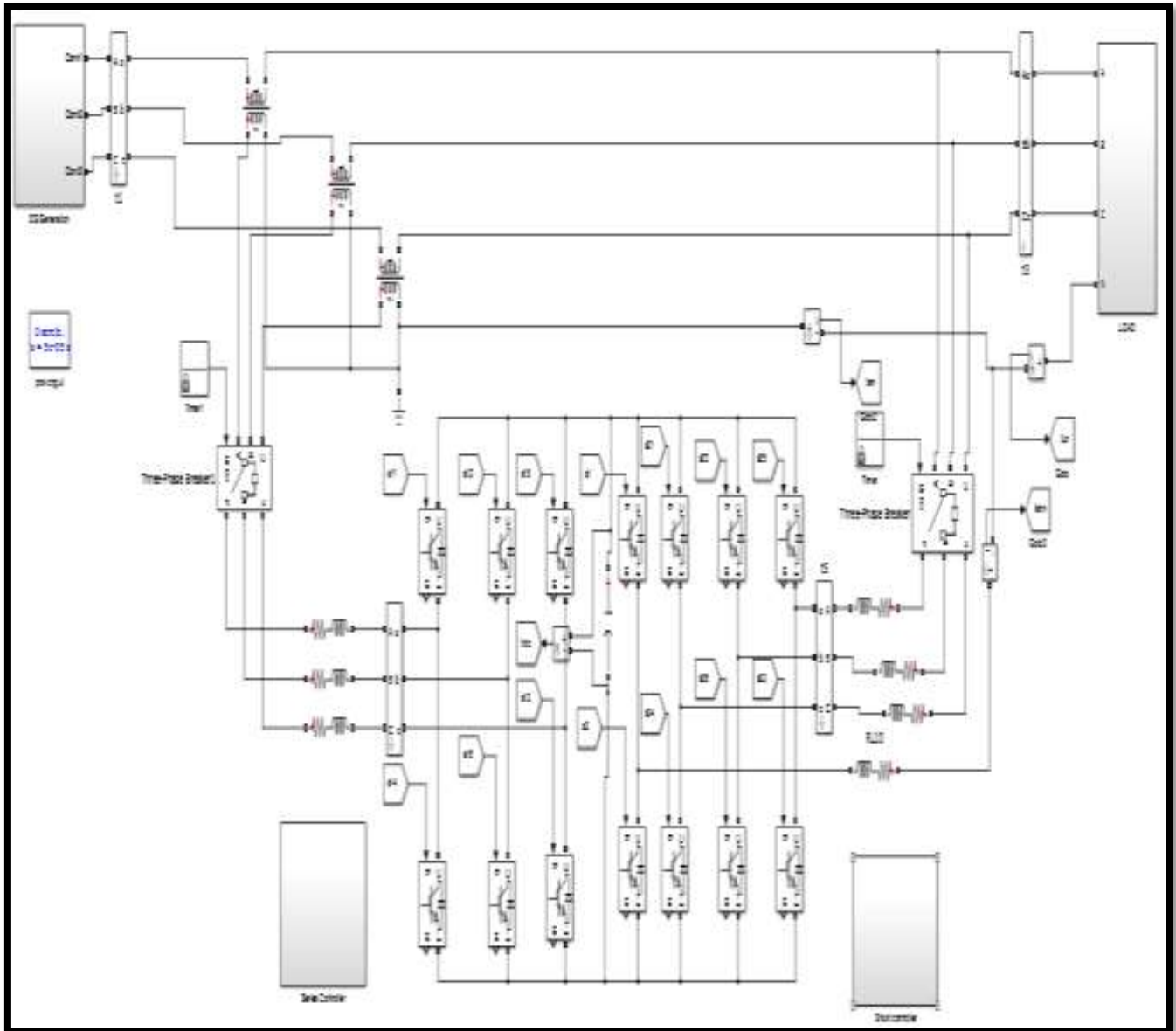

Figure3:TwelveSwitchCircuit

Proposed Ten Switch Circuit Block

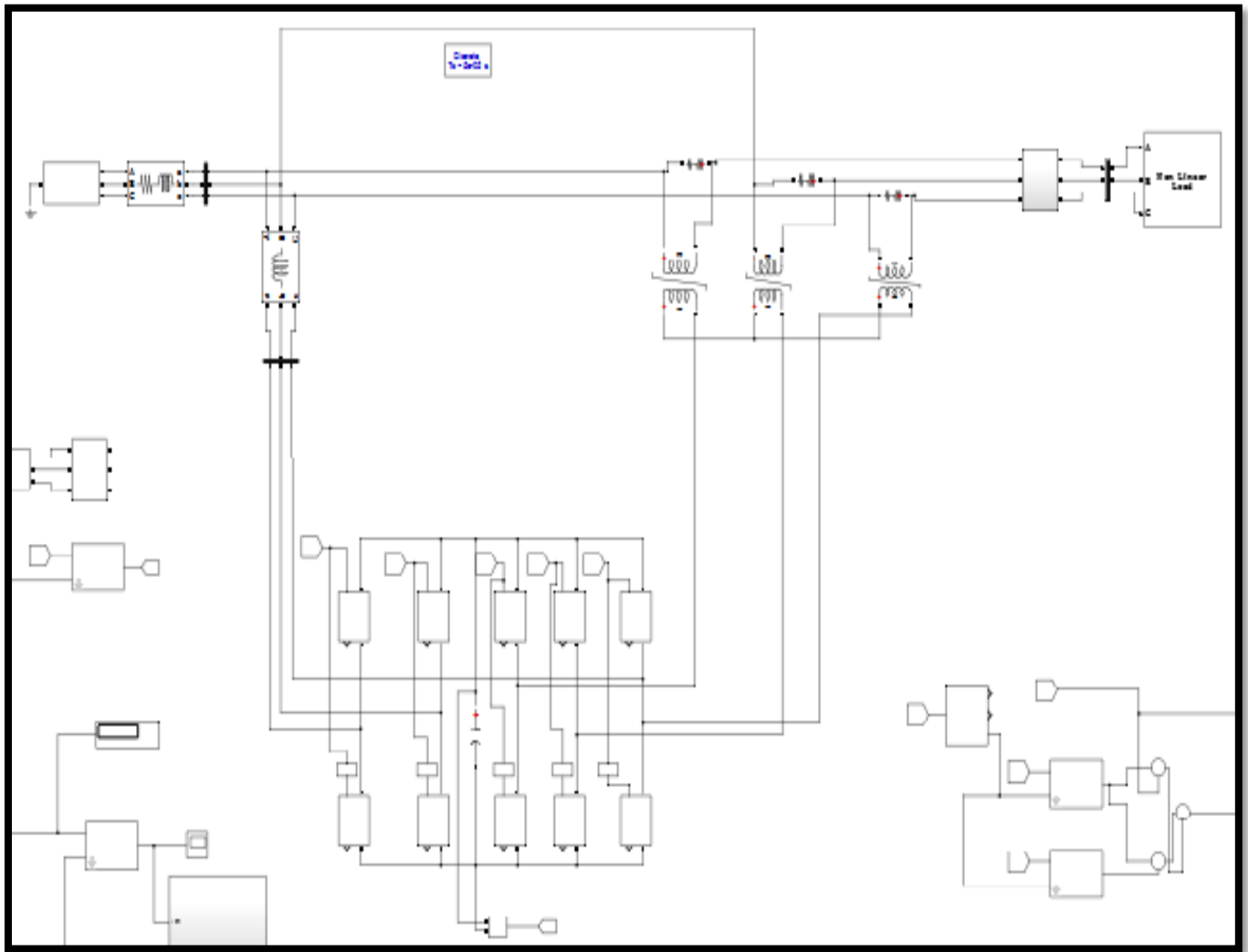

Figure4:Ten Switch Circuit

Simulation Result

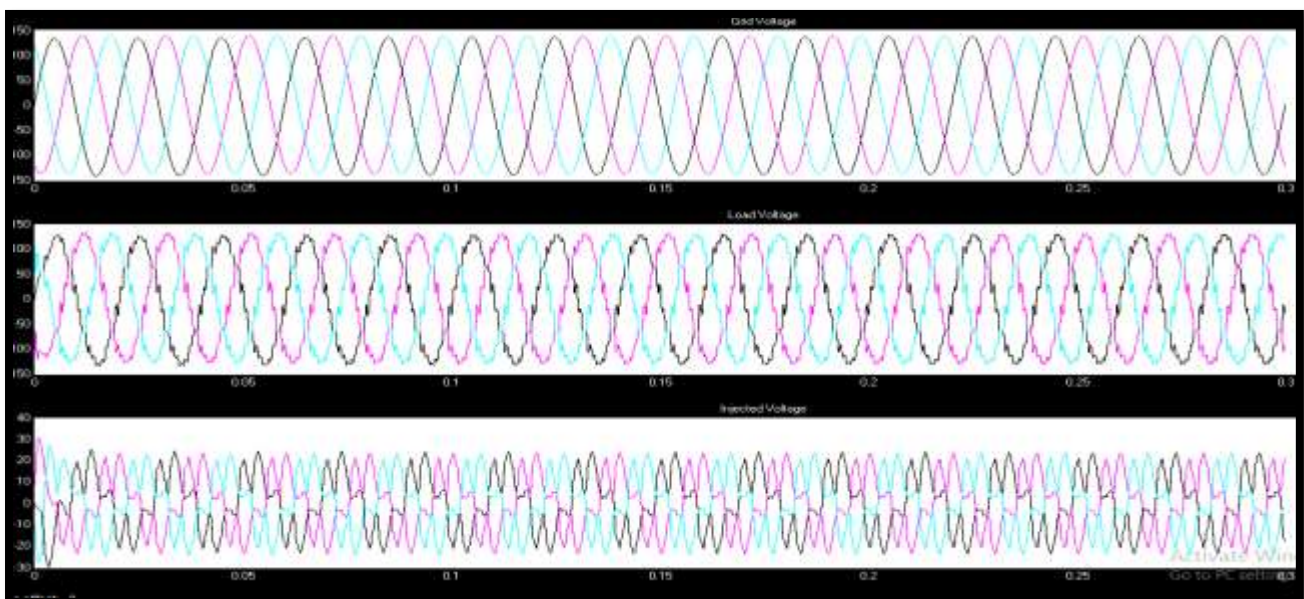

Figure5:Simulation Result

current accomplishing sinusoidal lattice streams with the THD of 2.1%. Therefore, the above test ponder confirms the practicality of the proposed ten-switch UPFC topology for useful applications to enhance the power factor.

5. Conclusion

This system proposed a novel UPFC employing novel ten-switch converter. The suggested configuration needs fewer switches and gate drive circuits. Therefore, the proposed topology results in reduction of installation area and cost. Also, PWM based switching algorithm has been presented for novel converter. Besides, control strategy of UPFC based on a suggested converter be described. The simulation results show that the proposed UPFC can operate according to control strategies against in the active and reactive power references sudden variations.

REFERENCES

- [1] J. M. Ramirez, J. L. Murillo-Pérez, "Steady-State Voltage Stability with StatCom", IEEE TRANS. ON Power Systems, Vol. 21, NO. 3, AUGUST 2006.
- [2] B. Han, H. J. Kim, S. T. Baek, "Performance analysis of SSSC based on three-level multi-bridge PWM inverter", Electric Power Systems Research, Vol.61, pp. 195-202, 2002
- [3] R. Tapia, J. M. Ramirez, "Power Systems Neural Voltage Control by a Statcom", International Joint Conference on Neural Networks Sheraton Vancouver Wall Centre Hotel, Vancouver, BC, Canada July 16-21, 2006.
- [4] A. T. Al-Awami, Y.L. Abdel-Magid, M.A. Abido, "A particle-swarm-based approach of power system stability enhancement with unified power flow controller", Electrical Power and Energy Systems, Vol.29, pp. 251-259, 2007.
- [5] S. T. Kalyani, G. T. Das, "simulation of real and reactive power flow control with UPFC connected to a transmission line", Journal of Theoretical and Applied Information Technology, pp. 16-22, 2008.
- [6] A. Shukla, A. Ghosh, A. Joshi, "Static shunt and series compensation of an SMIB System using flying capacitor multilevel inverter", IEEE Trans. Power Deliv. 20 (2005) 2613–2622.
- [7] D. Soto, T.C. Green, "A comparison of high-power converter topologies for the implementation of FACTS controllers", IEEE Trans. Indus. Electron. 49 (2002) 1072–1080.
- [8] A. K. Sadigh, M. Tarafdar Hagh, M. Sabahi, "Unified power flow controller based on two shunt converters and a series capacitor", Electric Power Systems Research, 80 (2010) 1511–1519.
- [9] C. Liu, B. Wu, N. Zargari, D. Xu, "A Novel NineSwitch PWM Rectifier-Inverter Topology for Three-Phase UPS Applications," European Conference on Power Electronics Applications, Sep. 2007.
- [10] T. Kominami, Y. Fujimoto, "A Novel Nine-Switch Inverter for Independent Control of two ThreePhase Loads", Industry Applications Conference, pp. 2346-2350, 2007.
- [11] S. M.D. Dehnavi, M. Mohamadian, A.Yazdani, F. Ashrafzadeh, "Space Vector Modulation for NineSwitch Converters", IEEE Trans. on Power Electronics, Vol. 25, No. 6, pp. 1488-1496, June 2010.

[12] M. R. Banaei, A. R. Dehghanzadeh, “Doubly Fed Induction Generator Based a Novel Nine Switch AC/AC Converter”, International Review on Modelling and Simulations, vol. 4, No. 2, pp. 562-567, April 2011.

[13] B. Mwinyiwiwa, B.Lu, B.T.Ooi, “Multi terminal unified power flow controller”, IEEE Trans. Power Electron. 15 (2000) 1088–1109.

[14] B.M. Hana, S.T. Baeka, H.J. Kima, J.B. Choob, G.S. Jang, “Novel unified power flow controller based on H-bridge modules”, Electron. Power Syst. Res. 70 (2004) 64–75.