

# A Review On Rfid, For Resolving Transport Related Issues.

*Prof. S. A. Annadate<sup>1</sup>, Mr. Mangesh S. Wadatkar<sup>2</sup>, Prof. Swapnil N. Jadhav<sup>3</sup>*

<sup>1</sup>Electronics & telecommunication Department, J.N.E.C.College of Engineering, B.A.M. University, Aurangabad, India.

<sup>2</sup>Electronics & telecommunication Department, J.N.E.C. College of Engineering, B.A.M. University, Aurangabad, India.,  
*mangesh.wadatkar@yahoo.com*

<sup>3</sup>Electronics & telecommunication Department, K.V.N.N.I.E.E.R .College of Engineering, S.P.P. University,

## Abstract:

Now a day's people don't have much time due to their intensive schedule. And roads have become much more crowded to drive. So everyone wants to reach the destination as early as possible. Therefore transportation has become a major issue. To overcome such problems Radio Frequency Identification (RFid) can be used. In this paper we would see how RFid can be used for transport related problems for Indian roads.

Here in collaboration with RFid we have also used Global System for Mobile Communication (GSM) and Enhanced Circuit Switched Data on GSM (ECSD) which has increased the range and scope of our project. Here we are going to see certain traffic problems and how we can overcome them using RFid.

**Keywords:** RFid, GSM, RFid tag, RFid reader, Sensors.

## 1. Introduction

In rapidly developing countries there is a problem of increasing number of vehicles on road. So the transportation is becoming a major issue. In earlier days traffic signals reduce the problems to a certain extent, but now people want to reach their destination as early as possible. Due to which the rate of accidents has gone higher and also we can see more traffic jams on certain roads where there is less intensity of vehicles. There are many problems due to traffic such as accident risk, environment hazards, violation of rules related to traffic, parking arrangement, toll administration, stealing of vehicles, street signal administration etc. So to solve such problems and to increase the speed of travelling, RFid can be used. RFid tag can store certain amount of information related to vehicle such as owner's info, RC book, insurance info etc.

Here we are using GSM module which contains small part in the vehicle which can transmit information related to any harmful event to the vehicle to different points. If any vehicle becomes accident affected, then this GSM module system acquires the information related to the location of accident through the RFid tags, which are installed on the road. This RFid tag sends the information to the GSM module. Then the accident news SMS is sent to a particular number such as police, hospital, ambulance, owner of the vehicle etc. Not only SMS is sent but also due to the accident, the vibration sensor which is placed in the vehicle gets activated. Due to which the digital camera becomes ON. This camera takes images, which are also sent to police, hospital, ambulance, owner of the vehicle etc. as MMS.

When any of the vehicles comes near a traffic signal, then the data or information stored in the RFid tag placed inside the vehicle is read. Taking this information, into consideration coming from all the vehicles at a particular signal. The traffic

density on a particular side of signal is also taken into consideration and a traffic signal is turned green or red. Due to this traffic is managed to certain extent automatically and smartly.

The vehicle insurance should be renewed in time. If it is not done so then the traffic police will receive a SMS regarding the details about the vehicle.

In the parking area, a RFid reader is installed. This reader reads the information of vehicle immediately when it enters the parking area. Then the reader allocates a particular area for parking the vehicle and also generates the bill when the vehicle moves out of the parking area. It is the same concept just like the automatic toll gate management system.

### 1.1 RFid

Radio frequency identification (RFid) technique is used widely since many years. It works just like a Barcode which contains certain amount of information. Now a day's it has become cheaper and so it is widely used everywhere.

- RFid operates on 125 - 134 KHz frequency range.
- RFid tags also consist of writable memory, which stores info which can be transferred to different RFid readers in various directions.
- RFid cards and readers have become cheaper.

There are huge improvements and developments to provide support in tracking cars or finding certain unwanted things and also in managing certain activities.

A simple RFid based system has three basic contents such as:

- a) An antenna,
- b) A transceiver consisting of a decoder,
- c) A RFid tag which is programmed with certain unique information.

Automatic vehicle identification tags can be further classified into different tags, based on the program and type of power source used.

The information stored in these tags is fixed (read only), and the tags cannot have any processing abilities. Smart Tags are used in combination with inline RF reader to convey information about the vehicle, customer, and account balance information to the toll system etc. Some portions of Rfid tag information are fixed (such as vehicle and customer data) while certain areas are updateable (such as balance information). The Smart Tag consists of microprocessor, which provides information about account balance that is been updated every time the smart tag is used.

## 1.2 GSM

Global system for mobile communication (GSM) is a world widely considered as a benchmark for digital cellular communication. GSM is European mobile telephone standard for a mobile cellular radio system which operates on 900 MHz. Now it is a great accomplishment to provide both low speed and voice, through the invention of cellular telecommunications. Various GSM based systems have been developed. The GSM standard is considered for addressing many problems. Now a day's mobile communications has become leading force for digital change. GSM provides voice and data communication with less power utilization.

## 2. Design and Implementation

The project is divided into five different sections such as on road section, vehicle section, traffic signal section, parking section and toll gate section. Let discuss each section in detail.

### 2.1 On road section:

Here in this section there are 'N' numbers of Rfid tags which can transmit the information related to area and generates alerts for special zones such as school, colleges, hospital etc. The range of this section is up to 50 meters with 64 Kbits of memory operating at frequency range of 902 MHz. The zonal information and alerts to the driver information is recorded in the tag. The alert information can be dynamically changed like damage in bridge, condition of road and new changes in road (one way or two ways and other diversion indications) etc.

### 2.2 Vehicle section:

In this section, Rfid reader is used. It also consists of Rfid tag which stores information related to the vehicle and the vehicle section also consist of 8051 embedded module and GSM module. In our project we have used SIM 300 GSM module which can transmit alerts to the mobile receivers which are initially configured. Rfid reader and GSM are used to receive and transmit data from the serial port of embedded module. Here the complete programming is done using embedded C language. The Rfid tags are used which can transmit vehicle information stored in it such as insurance details, RC book and license etc., to traffic controllers. This information is received by the Rfid reader near the traffic signals. This helps the traffic controllers to manage traffic in a smarter way and also traffic issues like insurance non-payment. Here in this section also consists of a digital camera for taking photos after accident and sent them as MMS to police, hospitals, ambulance etc. So that it will be helpful for relief operations, investigation and for security for avoiding theft at accident porn areas.

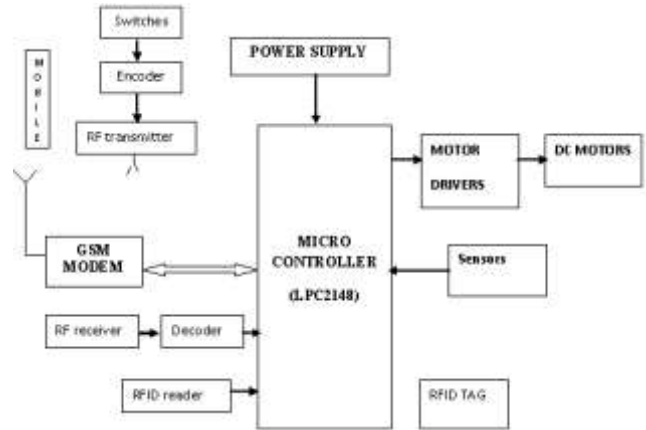

Figure 1: Vehicle section.

### 2.3 Traffic signal control section:

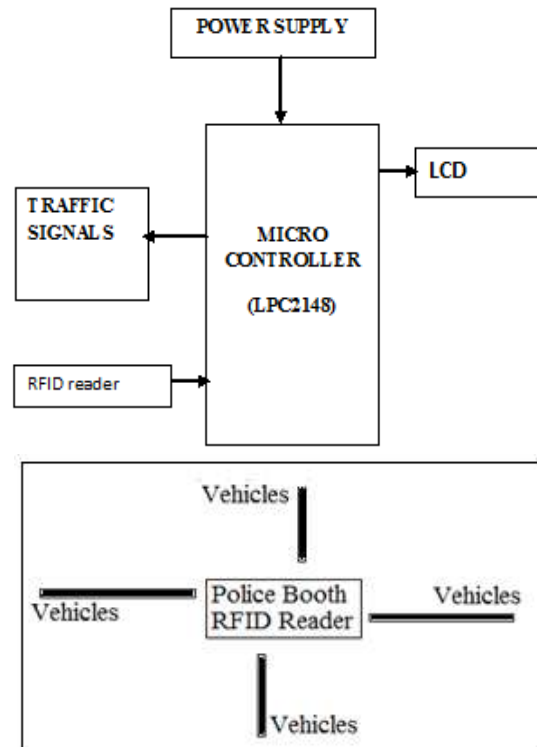

Figure 2: Traffic signal control section.

Normally the traffic signals changes from red green after certain time interval. That means every were the traffic signal are operated on time division bases. If there are more vehicles on a particular as compared to other, then also the traffic will be allowed to pass after a regular time allotted to every road. But here we can use a more advance and adaptive technique, which analyzes the amount of traffic on each road and then reduces the time of green signal on a particular road which consist of less number of vehicles. Here we have used microcontroller based Rfid reader which is connected through serial port to a system. In this module we require large number of antennas which are placed on different roads for gathering information. By using such type of technique for traffic signal, more amount of traffic problems can be solved to a greater extent. This technique is most effective during peak hours of traffic, where the vehicle density problems cannot arise. Very important thing regarding this technique is that it is cost

effective and can be widely used.

## 2.4 Parking slot management section:

As the name itself suggest that this module may be used for parking arrangement related problems. In this module microcontroller based RFid reader, IR sensors and stepper motor are used. Here we have used microcontroller based RFid reader, stepper motor & IR sensors which are connected through serial port to a system. The controller based RFid with IR sensors is used to sense the incoming or outgoing car as well as to allocate parking area. As the sensor's has to sense weather the parking area is vacant or not. It produces a signal to the system that a particular area is free and also it indicates the number of vacant slots where cars can be parked. It sense whether the vehicle is parked at the correct place. It also provides the system information about how much time the car was parked, so that the module can calculate the parking charges.

The stepper is just used for opening and closing of doors when the cars comes in or goes out. This type of parking system is widely used in many European countries which provide cheap and much accurate parking management in a much lesser time. This system also avoids crowding of cars near the parking area. Parking issues are solved to a certain extent without using manpower.

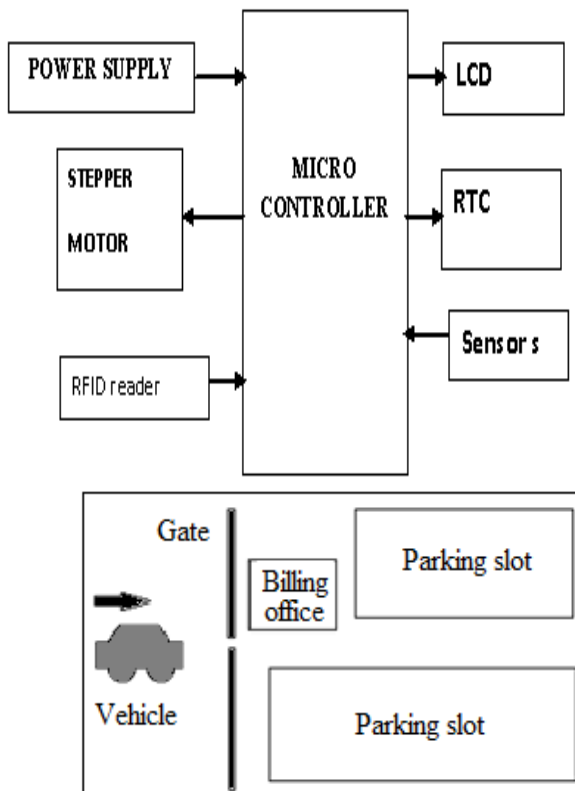

Figure 3: Parking slot management section.

## 2.5 Toll gate management section:

This section is same as that of parking slot management section. Here also we have used microcontroller, stepper motor and RFid reader. The vehicle number is recognized by the reader and bill is generated easily. Due to this we can automatically control toll gates by the use of simple RFid based system.

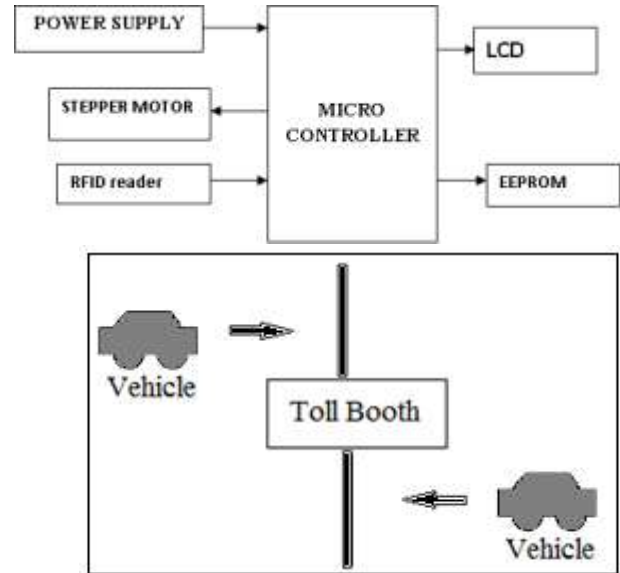

Figure 4: Toll gate management section.

## 3. Implementation

Project is implemented using LPC 2148(Arm 7),if any further modification is required for additional features, ARM 7 is better than 8051 .In Accident alert system unit, RFid Reader ,GSM module and vibration sensors are Interface with LPC 2148. In case of accident, vibration sensor generates large amplitude signal, which indicates accident has been taken place. Location of accident information is given by RFid reader .accident location information is send through GSM module. Location of accident is received with help of RFid reader and tag located at road side.

GSM module is connected to transmitter (Tx) of microcontroller serial port and RFid is connected to receiver of microcontroller serial port. Digital camera will record the accident, which can be utilized for studying the accident. Digital camera is also connected to system.

When vehicle is near to public places like hospital, school, market place, temple, RFid will give information regarding location, speed and safety instructions.

In traffic signal management unit, RFid tag is placed inside the vehicle. Information regarding Vehicle, its insurance and P.U.C test is stored and other vehicle related details are also included. Location of vehicle can be traced and in case of adverse situation information can be given to driver also very easily.

In traffic signal management, RFid reader near the signal can get information regarding the number of vehicles on different roads, with the help of RFid tags present inside the vehicle, Depending on vehicle present on different roads, timing of traffic signals can be varied, so that stop time of the vehicle at the signal can be reduced.

In parking slot management system, RFid reader can get information about number of vehicles, and size of vehicle, and at the exit gate, again the vehicle information can be read by RFid reader from the tag present inside the vehicle and the computer system at the parking can generate the bill for parking. At some airport, parking bill is generated on basis of stay time of vehicle in parking slot, accordingly bill is generated.

### 3.1 Advantages

1. Reduces the human efforts.
2. Enables specific identification of vehicles.
3. Multiple identification of vehicle is possible using RFid.
4. RFid tag provides high reliability.
5. Reduces time and money.
6. Least possible work stress.

### 3.2 Disadvantages

1. It is difficult to duplicate tags.
2. RFid tags takes power from the vehicle battery.
3. Tag installation is difficult.
4. In RFid Low frequency is used so data transmission rate is reduced.

### 4. Conclusion

In our project we have proposed a system which will give total solution for transport and traffic related problems such as parking management, traffic rules violation control, Toll gate control, traffic signal control and accident alert using RFid based system. It is a low cost, most effective solution for traffic related problems using RFid and GSM based technique. This is widely used in the developed countries such as USA, England, German and Japan. But as India is developing country, so this type of system is not yet implemented. And another cause is due to heavy investment for any automated system for transport management. Considering all these factors in mind we have implemented this simple and cost efficient RFid based system. This RFid based system will help in locating vehicles in the criminal cases like smuggling of goods, terrorism and it will also minimize the work load on check points.

### References

- [1] Manish Buhptani, Shahram Moradpour, "RFID Field Guide -Developing Radio Frequency Identification Systems," Prentice Hall, 2005, pp 7-9, 16-225, 160, 231.
- [2] Sewon Oh, Joosang Park, Yongioon Lee, "RFID-based Middleware System for Automatic Identification," IEEE International Conference on Service Operations and Logistics, and Information, 2005.
- [3] Shi-Cho Cha Kuan-Ju Huang Hsiang-Meng Chang, "An Efficient and Flexible Way to Protect Privacy in RFID Environment with Licenses," IEEE International Conference RFID, April 16-17,2008.
- [4] Kin Seong Leong, Mun Leng Ng, Member, IEEE, Alfio R. Grasso, Peter H. Cole, "Synchronization of RFID Readers for Dense RFID Reader Environments," International Symposium on Applications and the Internet Workshops (SAINTW'06), 2005.
- [5] Raj Bridgelall, Senior Member, IEEE, "Introducing a Micro-wireless Architecture for Business Activity Sensing," IEEE International Conference RFID, April 16-17,2008.
- [6] Urachada Ketprom, Chaichana Mitrpant, Putchapan Lowjun, "Closing Digital Gap on RFID Usage for Better Farm Management," PICMET 2007, 5-9 August 07.
- [7] S.Srinivasan, Dr.H.Ranganathan and S.Vani, "An Embedded System and Rfid Solution For Transport Related Issues," IEEE 2010, Volume 1, 978-1-4244-5586-7.

- [8] Sachin Bhosale and Dnyaneshwar Natha Wavhal, "Automated Tollplaza System Using Rfid," International Journal of Science, Engineering and Technology Research, Volume 2, Issue 1, January 2013, ISSN: 2278 – 7798.
- [9] Manish Buhptani, Shahram Moradpour, "RFID Field Guide -Developing Radio Frequency Identification Systems," Prentice Hall, 2005, pp 7-9, 16-225, 160, 231.
- [10] Sewon Oh, Joosang Park, Yongioon Lee, "RFID-based Middleware System for Automatic Identification," IEEE International Conference on Service Operations and Logistics, and Information, 2005.
- [11] Shi-Cho Cha Kuan-Ju Huang Hsiang-Meng Chang, "An Efficient and Flexible Way to Protect Privacy in RFID Environment with Licenses," IEEE International Conference RFID, April 16-17,2008.
- [12] Raj Bridgelall, Senior Member, IEEE, "Introducing a Microwireless architecture for Business Activity Sensing," IEEE International Conference RFID, April 16-17,2008.
- [13] Rahman and Rohisyam, "Case Study: Malaysian Smart Shelf," <http://www.rfid-asia.info/2007/07/case-studymalaysian-smart-shelf.htm>. Retrieved 2007-08-03.
- [14] N. E. Fenton and S. Pfleeger, Software Testing, Thomson Asia, 2007.
- [15] Urachada Ketprom, Chaichana Mitrpant, Putchapan Lowjun, "Closing Digital Gap on RFID Usage for Better Farm Management," PICMET 2007, 5-9 August.
- [16] Markus Hansen, Sebastian Meissner: Identification and Tracking of Individuals and Social Networks using the Electronic Product Code on RFID Tags, IFIP Summer School, Karlstad, 2007.
- [17] Kin Seong Leong, Mun Leng Ng, Member, IEEE, Alfio R. Grasso, Peter H. Cole, "Synchronization of RFID Readers for Dense RFID Reader Environments," International Symposium on Applications and the Internet Workshops (SAINTW'06), 2005.

### Author Profile

**Prof. S. A. Annadate** He is working as a Professor at J.N.E.C, Aurangabad under B.A.M. University. He has also guided many U.G and P.G student's projects.

**Mr. Mangesh S. Wadtkar** received his B. E. degree in Electronics and telecommunication engineering from K.K.W.C.O.E., Nashik under S.P.P University in 2009 and also pursuing M.E. degree from J.N.E.C, Aurangabad under B.A.M. University. He is working as an Assistant Professor at B.V.C.O.E, Nashik under S.P.P. University.

**Prof. Swapnil N. Jadhav** received his B. E. degree in Electronics and telecommunication engineering from S.E.S.C.O.E., Dhule under North Maharashtra University in 2006 and also pursuing M.E. degree in Embedded systems from M.I.T., Aurangabad under B.A.M. University. He is working as an Assistant Professor at K.V.N.I.E.E.R., Nashik under S.P.P. University. He has published many papers in National/International Journals. He has about 6.5 years of teaching experience. He has also guided many U.G student's projects

