

Performance Evaluation of Different Types of CMOS Operational Transconductance

Vijeta¹, Dr. Subodh Wairya²

¹ Electronics Engineering Department, Institute of Engineering & Technology,
Gautam Buddh Technical University,
Lucknow-226021, U.P, India
viijeta203@gmail.com

²Associate Professor
Electronics Engineering Department, Institute of Engineering & Technology,
Gautam Buddh Technical University,
Lucknow-226021, U.P, India
swairya@ietlucknow.edu

Abstract: The Operational Transconductance Amplifier is a basic building blocks found in many analog circuits such as data converter's (ADC & DAC) and Gm-c filters. The OTA is an amplifier whose differential input voltage produces an output current. Thus, it is a voltage controlled current source (VCCS) whereas the Op-amp are voltage controlled voltage source (VCVS). There is usually an additional input for a current to control the amplifier's transconductance. The paper represents the different topology of CMOS OTA is described and at last comparison between different configuration is given.

Keywords: Telescopic cascode OTA, Gain boosting OTA, Folded cascode OTA, Floating gate OTA.

1. Introduction

Today's competitive, manufactures and developers are searching ways to build high performance devices that are smaller in size, operate at low power and lighter in weight. Low static power consumption, full rail dynamic range, characteristics as well as it is ease of scaling creates the perfect combination for the high performance integrated circuit (IC).

The Operational Transconductance Amplifier (OTA) is the block with the highest power consumption in analog integrated circuits in many applications. Low power consumption is becoming more important in handset devices, so it is a challenge to design a low power OTA. There is a trade-off between speed, power, and gain for an OTA design because usually these parameters are contradicting parameters. There are four kind of OTA: two stage OTA, Folded-cascode OTAs, and Telescopic OTAs. The Telescopic amplifier consume the least power compared with the other two amplifiers, so it is widely used in low power consumption applications. It has also high speed compare to other two topologies [1][2][8].

2. OTA concept

An operational transconductance amplifier is a voltage input, current output amplifier. The input voltage V_{in} and

the output current I_o are related to each other by a constant of proportionality and the constant of proportionality is transconductance "gm" of amplifier. In the ideal OTA, the

output current is a linear function of the differential input voltage, calculated as follows:

$$I_{out} = (V_{in+} - V_{in-}) \cdot g_m \quad (1)$$

Where V_{in+} is the voltage at the non-inverting input, V_{in-} is the voltage at the inverting input and g_m is the transconductance of amplifier.

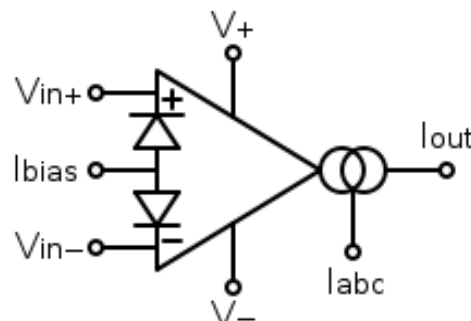

Figure 1: OTA symbol

The amplifier's output voltage is the product of its output current and its load resistance.

$$V_{out} = I_{out} \cdot R_{load} \quad (2)$$

The voltage gain is then the output voltage divided by the differential input voltage .

$$G_{\text{voltage}} = \frac{V_{\text{out}}}{(V_{\text{in}+} - V_{\text{in}-})} = R_{\text{load}} \cdot g_m \quad (3)$$

The transconductance of the amplifier is usually controlled by an input current , denoted I_{abc} (amplifier bias current) . The amplifier's transconductance is directly proportional to this current. This is the feature that makes its useful for electronic control of amplifier gain.

3. Different OTA topology

There are six type of OTA topologies . Each topology has its own advantage and disadvantage.

3.1. Single stage OTA

Single stage OTA is as shown in fig 2. This single stage OTA is less complex compare to other type of OTA topology. Because of its less complex property its speed is higher compare to other topology.

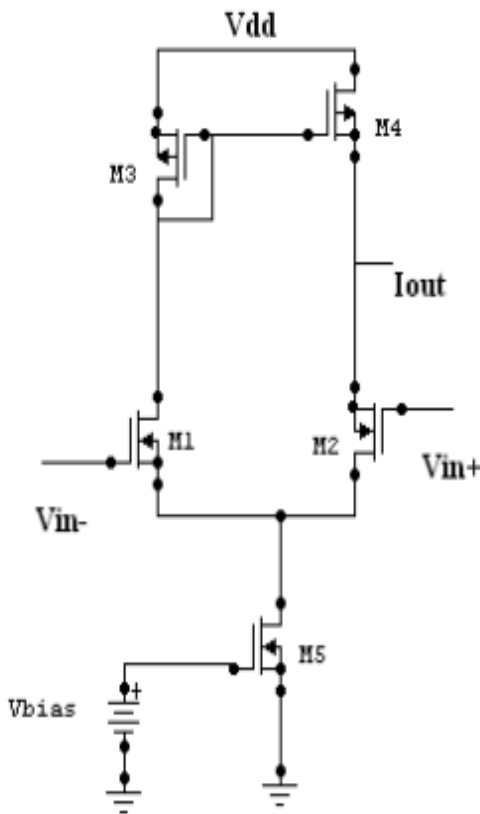

Figure 2: Single stage OTA

The drawback of this type of OTA is lower gain due to the fact that output impedance of this type configuration is relatively low. However this low impedance also leads to high unity gain bandwidth and high speed [3].

3.2. Two stage OTA

The drawback of having limited gain of the single stage OTA is overcome by two stage OTA . In this type of configuration two stages are used. One of them provides high gain followed by second stage which provides high voltage swing. This modification increases the gain up to some certain extent compared to single stage OTA. But this addition of extra stage also increase complexity. And the increased complexity will

reduce the speed in comparison to a single stage amplifier[3][4].

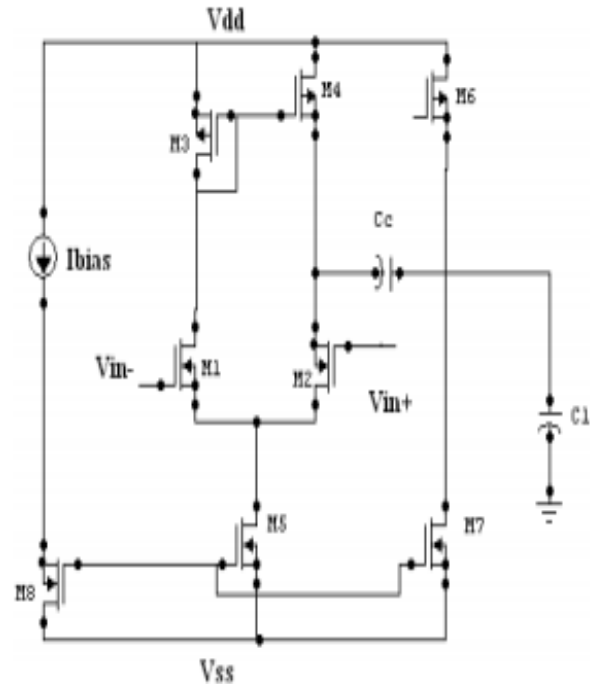

Figure 3: Two stage OTA

Advantage :

- 1.It has high output voltage swing.
- 2.It has higher gain compare to single stage OTA.

Disadvantage:

- 1.It has a compromised frequency response.
- 2.This topology has high power consumption because of two stage in its design.
3. It has a poor negative power supply rejection at higher frequencies.

3.3 Telescopic cascode OTA

The telescopic cascode OTA configuration is as shown in fig 4, single stage OTA have low gain due to fact that it has low output impedance, one way of increasing the impedance is to add some transistors at the output is to add some transistors at the output including using an active load. Transistors are stacked on top of each other. The transistors are called "cascode", and will increase the output impedance and will increase the gain [1][2][8].

Advantage :

1. It provides higher speed.
2. It has lower power consumption.

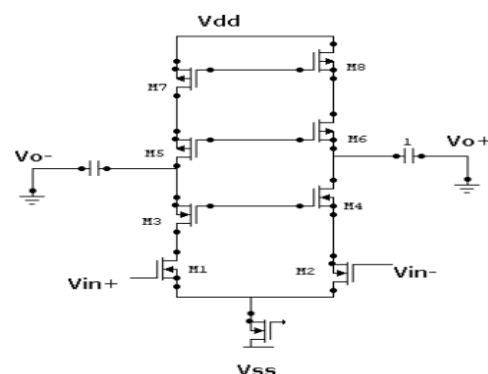

Figure 4: telescopic OTA

Disadvantage :

1. limited output swing.
2. shorting the input and output is difficult.

3.4 Regulated cascode (Gain Boosting) OTA

In this type of configuration gain is further increased without decreasing output voltage swing i.e. gain is further increased without adding more cascode devices. The regulated cascode OTA is shown in fig 5.

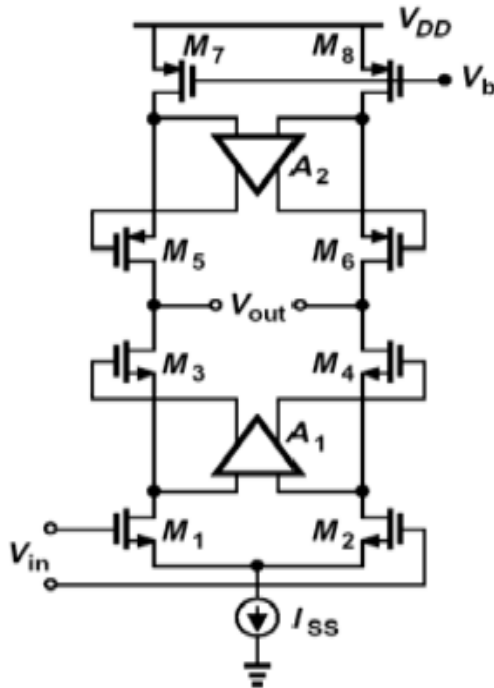

Figure 5: Gain boosting OTA

The drawback of this configuration is that these extra amplifier might reduce the speed of the overall amplifier . Hence, they should be designed to have a large bandwidth so as not to affect the bandwidth of the entire configuration [5][6].

3.5 Folded cascode OTA

In order to remove the drawback of telescopic OTA i.e. limited output swing and difficulty in shorting the input and output a Folded cascode OTA is used . The fig of Folded cascode OTA is shown in fig 6 [7].

Advantage :

- 1.This design has corresponding superior frequency response than two stage operational amplifiers.
- 2.It has better high frequency Power Supply Rejection Ratio (PSRR) . The power consumption of this design is approximately the same as that of the two stage design.

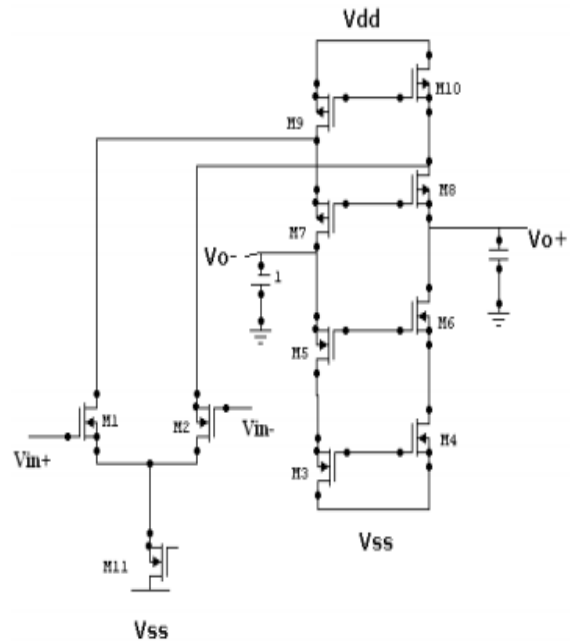

Figure 6: Folded cascode OTA

Disadvantage :

- 1.Folded cascode has two extra current legs ,and thus for a given settling requirement ,they will double the power dissipation.
- 2.The Folded cascode stage also has more devices, which contribute significant input referred thermal noise to the signal.

3.6. Floating Gate OTA

Floating gate MOSFET transistors are widely used in digital world as EPROM(erasable programmable read only memories) and EEPROM (electrically erasable programmable read only memories), but the trend these days is to use them as circuit elements, as it will be shown in this paper.

Operational Transconductance Amplifier or OTA is a key functional block used in many analog and mixed- mode circuits. In point of fact, it is usually more desirable than any ordinary amplifier because of its high output impedance. The circuit presented here is a two stage transconductance amplifier. The scheme uses p-channel floating gate transistors at the input, M1 and M2 each with two gates. Of course, it is possible to use a complementary scheme with n-channel input transistors. As specified by the name , the circuit is the cascade of two stage: The first is a differential amplifier which consists of input devices M1, M2 and current mirror M3,M4 which is acting an active load. The second stage is a conventional inverter with M5 as drives and M6 as active load. See fig 7 [9][10].

Advantage :

- 1.This design reduced power consumption.
2. need low power supply
- 3.high output Impedance
- 4.low leakage current.

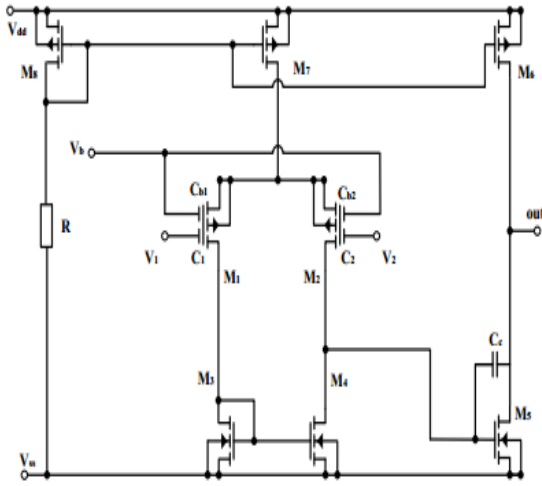

Figure 7: The circuit of two stage OTA using FG-MOSFETs

Disadvantage:

Floating gate MOS has certain limitations like isolated Floating gate , which may accumulated static charge ,give low frequency response and need large chip area.

4. Comparison in different type of OTA topology

The table presents a comparison of basic Op-amp parameters for different configurations above [8][9].

Table 1. Comparison

Topology	Gain	Speed	Power consumption
Two stage	High	Low	Medium
Telescopic cascode	Medium	Highest	Low
Gain boosted	High	Medium	Highest
Folded cascode	Medium	High	Medium
Floating gate	High	High	Lowest

5. Conclusion

In this paper basic concept of OTA is described. Different topology of OTA is also described along with its advantage and disadvantage .Comparison of this topology is also described.

References

[1].LiTi anwang, Ye Bo, and Jiang Jingnang, “A Novel Fully Differential Telescopic Operational Transconductance Amplifier” Journal of semiconductors, Vol.30, No. 8 August 2009.
 [2] Kush Gulati and Hae-seung Lee, “ A High Swing, High Performance CMOS Telescopic Operational Amplifier”,IEEE Journal of Solid- State circuits, Vol.33, No.12,December 1998.
 [3] Antonio J. Lopez- Martin, “ Low- Voltage Super Class AB CMOS OTA Cell With Very High Slew Rate And Power
Dr. Subodh Wairya received B. Tech (1993), M.Tech and Ph.D (2012) from HBTI, Kanpur, Jadavpur University, Kolkata and

Efficiency”, IEEE Journal of solid - state circuits, Vol.40,No.5, May 2005.

[4] Hitesh Modi, Nilesh D. Patel ,“ Design And Simulation Of Two Stage OTA Using 180nm And 350nm Technology”, International Journal of Engineering and Advanced Technology (IJEAT), ISSN:2249-8958,Volume-2,Issue-3, February 2013.

[5] Thomas Burger and Qiuting Huang, “ On The Optimum Design Of Regulated Cascode Operational Transconductance Amplifier”, Swiss Federal Institute of Technology, Integrated system Laboratory CH-0892 Zurich,Switzerland.

[6] D.Nageshwara Rao, S.Venkata Chalamand, V. Malleswara Rao, “ Gain Boosted Telescopic OTA With 110db Gain And 1.8 Ghz UGF”, International Journal of Electronics Engineering Research, ISSN 0975-6450 Volume.2 No.2(2010)pp. 159-166.

[7] Djeghader Redouane and Nour Eddine Bougachel, “Design Choice For Folded Cascode Operational Transconductance Amplifier”, IC Design lab, University Hadj Lakhdar, Batna , Algerie, African Physical Review (2008),2 special Issue(Microelectronics):0039.

[8] R. Jacob Baker, Harry W.Liand David E.Boyce, “CMOS circuit design, layout and simulation”, IEEE Press series on microelectronics systems, Prentice Hall of India Private Limited,2014.

[9] Ziad Alsibai, “Floating - Gate Operational Transconductance Amplifier” International Journal of Information and Electronics Engineering , Vol.3, No.4, July 2013.

[10] Rockey Gupta and Susheel Sharma, “ Voltage Controlled Resistor Using Quasi- Floating Gate Mosfets” Maejo International Journal of Science and Technology 2013,7(01), 16-25, ISSN 1905-7873.

Author Profile



Vijeta received the B. Tech degree in Electronics and Communication Engineering from FGIET, Raebareli, Uttar Pradesh Technical University, India and is currently working towards her M. Tech degree in Microelectronics with the research interest in Increasing gain and speed and decreasing power consumption of OTA, form Institute of Engineering and Technology, Uttar Pradesh Technology University, Lucknow, India.



MNNIT Allahbad, India, respectively. His Ph.D research work was oriented towards PERFORMANCE EVALUATION OF HIGH

SPEED LOW POWER CMOS FULL ADDER CIRCUITS FOR LOW VOLTAGE VLSI DESIGN. Currently, he is an Associate Professor at IET, lucknow(from 6 May 1996- Present).He has also served as Scientist “B” Adhoc (One Year) at DRDO, Lucknow during January, 1995-January, 1996 and Graduate Engineer under Consultancy Project at HAL, Lucknow during From January, 1994-January, 1995 (one year). Also he is one of the authors of a book entitled “A Simplified Approach to Telecommunication and Electronic Switching Systems” by C.B.L. Srivastav, Neelam Srivastava & Subodh Wairya Published by Dhanpat Rai and Company in the year 2006.