

# E-Field Uniformity Test Volume In Gtem Cell Based On Labview

Dominic S. Nyitamen

Electrical Electronic Engineering Department, NDA, Kaduna Nigeria  
dsnyitamen@nda.edu.ng

**Abstract**— The standard IEC 6100-4-20 is used to carry out field uniformity in GTEM 5407 using Labview as the controlling software. For reliable and reproducibility of measurements in the GTEM, determine the field distribution to ensure the field uniformity for the performance of emissions and immunity tests is a requirement. In this work the determination of electric field distribution which is a lengthy process is carried out employing the Labview software for automatic capturing and storage at each point of measurement all the needed parameters in the frequency range of interest. The selected working volume chosen showed the primary field within 0 – 6dB required by the standard as well as – 6dB cross coupling separation. The GTEM working volume was prepared for total radiated power test for GSM900 phone.

**Keywords**— GTEM, Labview, E-probe, emissions, susceptibility, septum, propagation.

## I. INTRODUCTION

The gigahertz transverse electromagnetic mode, GTEM, has gained acceptance as a major EMC test environment for radiated and susceptibility measurements. Its ease of operation is an advantage. It's near zero interference, low cost and small size compared to anechoic room and the reverberation chamber is another attraction. The volume of the GTEM has broadband characteristics, usually with usable frequency range from DC to several GHz [1-3]. The electric and magnetic field distribution of the GTEM is well defined. The field strength distribution is a function of the input power, the particular location in the longitudinal direction and the height of the septum corresponding to the location.

The focus of this work is the study of electric field distribution in an unloaded GTEM cell, which contributes to the general understanding of radiated immunity test in electromagnetic compatibility. A uniform electric field distribution is required so that the device under test will be evenly illuminated by the electromagnetic field. A vertical plane transverse to the direction of propagation is selected and tested for field uniformity.

The non uniformity may be caused by the following factors [4]: The field distribution caused by the geometry of the intersections and the increase of the septum's height along the z-axis

The appearance of higher modes other than the TEM mode at certain frequencies that have the electric or magnetic field directed in the direction of propagation

The amplitude ripples caused by standing wave due to an improper termination especially at the higher frequencies.

For reliable and reproducibility of measurements in the GTEM, it is important to first determine the field distribution and to ensure the field uniformity for the performance of emissions and immunity tests. This process is lengthy and not easy for small cells[short papers] as several points needs to be measured within the GTEM volume over the entire frequency range as required in the IEC1600-4-20 standard. In this work the determination of Electric field distribution which is lengthy is carried out employing the Labview software for automatic capturing and storage for each position in the frequency range.

With the Labview, the field sensor (with outputs in x-,y-,z-components) are captured while simultaneously recording the input power with the power meter, and the frequency which is varied from the signal generator in the range of interest for each test position in the GTEM cell..

## THE GTEM CELL

Electrically, the GTEM is an extension of a 50-ohm transmission line. The transmission line's outer conductor flares and expands into a pyramidal form, becoming the GTEM's outer walls and RF shield. The center conductor transforms into a thin, wide conductive plate, becoming the GTEM's septum. Current is terminated by a 50 ohm broadband resistive network between the septum and the GTEM's backwall. Fields are terminated by RF absorber at the backwall [5]. The attraction in GTEM includes a constant characteristic impedance of 50 ohms throughout its length and field uniformity within the working volume. The characteristic impedance is based on the geometrical dimensions. To avoid reflections that may cause higher order modes, the characteristic impedance must be maintained along the length of the cell [6,7]

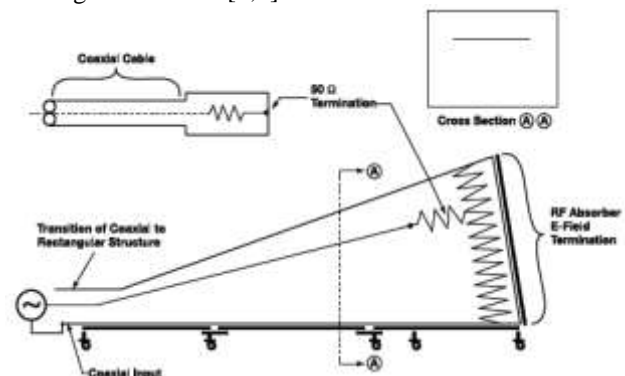

Fig. 1. GTEM in components[5]

The mode of propagation of the electromagnetic wave in the GTEM is TEM with the electric field given as [7]:

$$E = \frac{V_{in}}{h} = \frac{\sqrt{P_{in} Z_o}}{h}$$

Where,

$V_{in}$  = input voltage  
 $P_{in}$  = input power  
 $h$  = height of the septum plate above the horizontal bottom ground plane at the point of measurement  
 $Z_0$  = the characteristic impedance of the GTEM cell.

TEM waves will propagate around the septum of the GTEM cell when high frequency signals are input. The waves propagating along the septum are characterised by electric and magnetic fields that are transverse to the direction of propagation. The phase velocity of the TEM mode for propagation in free space and TEM waveguides is always equal to the speed of light.

### ELECTRIC FIELD STRENGTH

The strength of the electric field is proportional to the applied voltage and the distance between the flat inner conductor (septum) and the outer conductor. Figure 2 shows the typical field strength pattern at the cross section of testing volume. The nominal field strength in the working volume refers to the field strength at the center of testing volume approximately the fraction of the voltage and the distance between inner conductor and bottom outer wall.

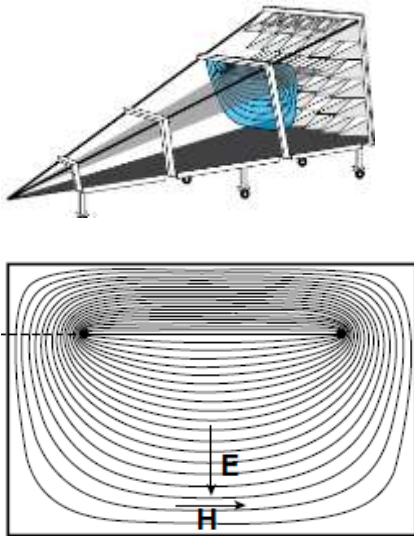

Fig. 2 Field distribution in GTEM [5]

### MEASUREMENTS

Measurement setup is shown in fig 3. The equipment involved in the process include: GTEM cell (5407 model), Signal Generator 5060 series Amplifier, Power meter E4419 EPM series/power sensor, 30dB Directional Coupler, Field probe-RAdisense (The probe is an active device, which detects the electric field levels and converts the data to a digital form, which is sent to the receiver through fiber optic link), IEEE488 (USB-GIPB), Desktop computer with NI Labview software.

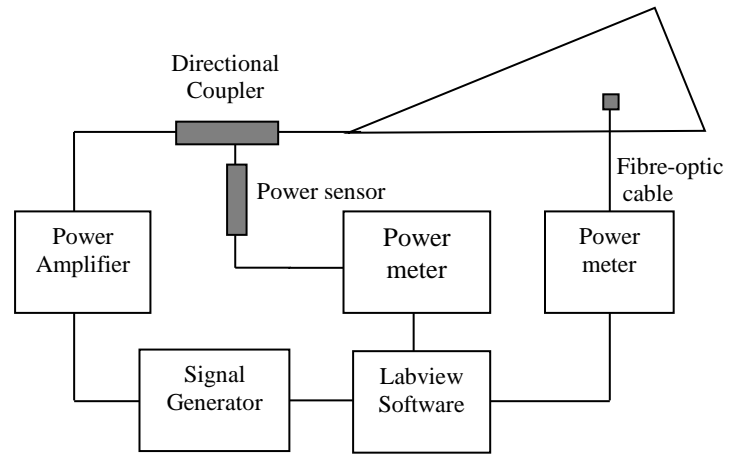

Fig 3 Measurement Setup

Figure 6 shows the grid size used for the uniform area as required by IEC 61000-4-20. For a 0.5 m by 0.5 m area an extra central point would have to be added to a 4-point grid.

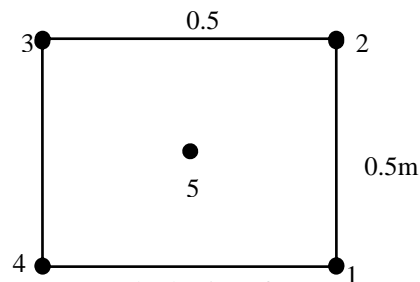

Fig. 4 Layout and selection of measurement points

### CONSTANT FORWARD POWER METHOD BS 61000-4-20 [8]

The standard suggests grid sizes for a test volume to be applied depending on the size of the GTEM. The procedure for carrying out the calibration is known as the “constant forward power” method and is as follows:

- position the isotropic electric field strength sensor at one of the points in the grid;
- apply a forward power to the TEM waveguide input port so that the electric field strength of the primary field component is in the range 3 V/m to 10 V/m, through the frequency range, in frequency steps specified and record all the forward power, primary and secondary components field strength readings;
- with the same forward power, measure and record the primary and secondary field strengths at the remaining grid points;
- taking all grid points into consideration, delete a maximum of 25 % (4 of 16, 2 of 9, 1 of 5) of those grid points with the greatest deviation from the mean value of the primary field component, expressed in V/m;
- the primary field component magnitude of the remaining points shall lie within a range of 6 dB. The level of the secondary field components shall not exceed -6 dB of the primary field component at each of these points;
- of the remaining points, take the location with the lowest primary field component as the reference (this ensures the 0 - +6dB requirement is met);
- from knowledge of the forward power and the field strength, the necessary forward power for the required test-field strength can be calculated (for example, if at a given point 81 W gives 9 V/m, then 9 W is needed for 3 V/m). This shall be recorded.

Depending on the size of the uniform area it is calibrated at least with a number of measurement points. A field is considered uniform if the following requirements are fulfilled:

- the magnitude of the primary electric field component over the defined area is within  $-0+6\text{dB}$  of the nominal primary field component, over at least 75 % of the measured points;
- the magnitudes of both secondary (unintended) electric field components are at least 6 dB less than the primary component, over at least 75 % of the measured points.

The 75 % of points fulfilling the first requirement does not need to be identical with the 75 % of points fulfilling the second requirement. At different frequencies, different measured points may be within the tolerance. The tolerance has been expressed as  $-0+6\text{dB}$  to ensure that the field strength does not fall below nominal. The 6 dB tolerance is considered to be the minimum achievable in practical test facilities.

The three components of electric field (vertical and horizontal and the longitudinal) are captured by the Labview interface. The accuracy in measurement of the electric field is affected by the secondary (unwanted) fields. It is therefore required to find the region for the working volume where the primary (vertical) component dominates with greater cross polarisation isolation. In this work, the cross polarisation isolation is estimated. The maximum electric field difference between the secondary fields and primary field in 4 out of 5 positions of measurement are obtained.

### RESULTS and DISCUSSION

The field uniformity test was performed for five (5) points with the grids 500mm x 500mm at the septum height of 780mm in the GTEM 5407. Of the 5 points used, at each frequency 1-point with the highest diversity was discarded which gives the 75% tolerance [9]. The maximum difference in the vertical E field for the remaining 4-points is shown in Fig. 5.

The result shows that for the working volume selected, the GTEM is well within the 6dB tolerance over the entire frequency range of 80MHz to 1GHz. The volume was chosen for radiation test for a GSM 900 phone and could serve effectively for small portable devices operating within this range.

The cross-polar coupling test to ensure the secondary component are lower than the primary (vertical) field by 6dB was also carried out. The horizontal and the longitudinal fields are plotted relative to the primary field in Fig.6. This is repeated relative to the resultant electric field in Fig.7. Additionally, the cross coupling separation is shown in Fig.8(a-e). For all the 5-points in the working volume. It can be seen clearly in all the plots the separation is well in excess of  $-6\text{dB}$ .

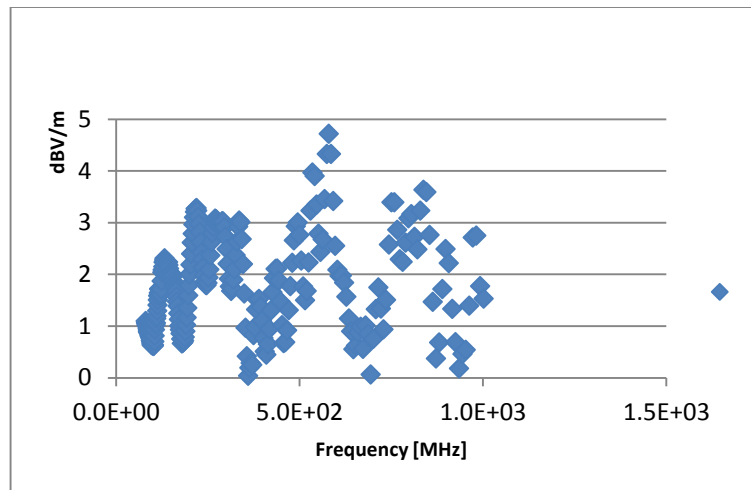
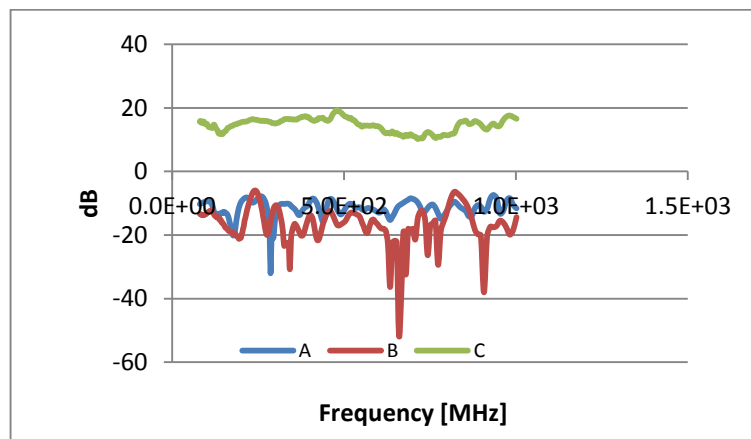
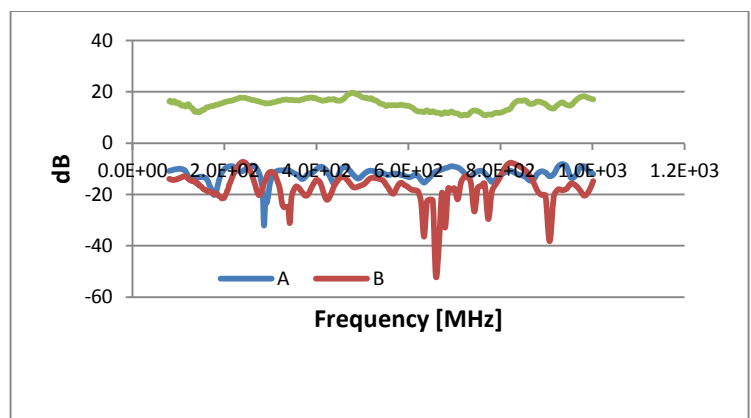

Fig.5 Maximum difference for 4 of 5 points, with reference to the primary field



A & B =horizontal and longitudinal fields relative to primary field. C= primary field

Fig.6 Primary field and the relative secondary fields



A & B =horizontal and longitudinal fields relative to resultant field. C= resultant field

Fig.7 Resultant field and the relative secondary fields

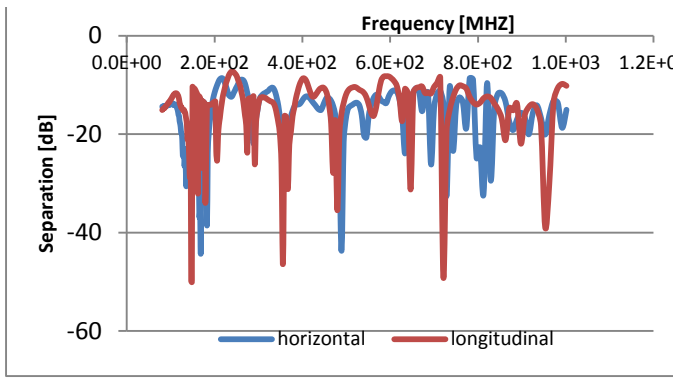

Fig.8a Position 1

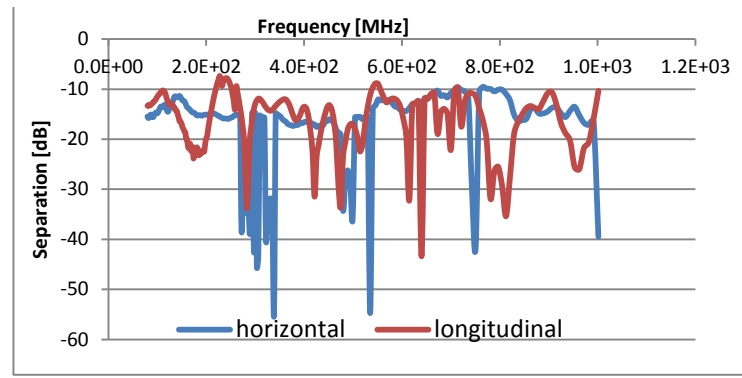

Fig.8e Position 5

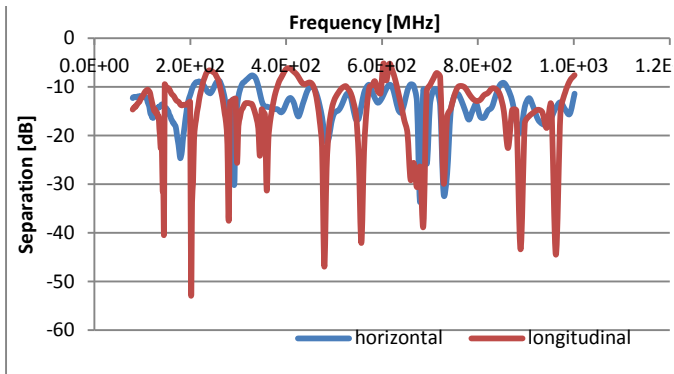

Fig.8b Position 2



Fig.9 I abview front panel

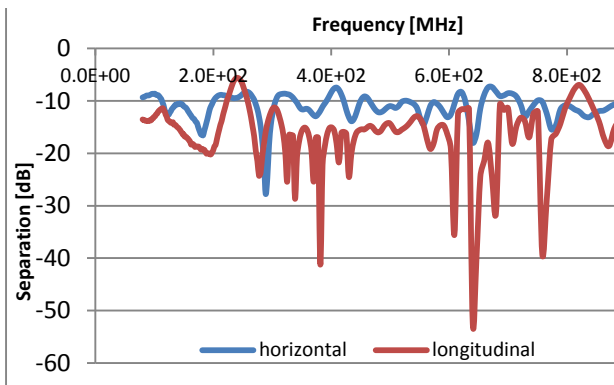

Fig.8c position 3 separation

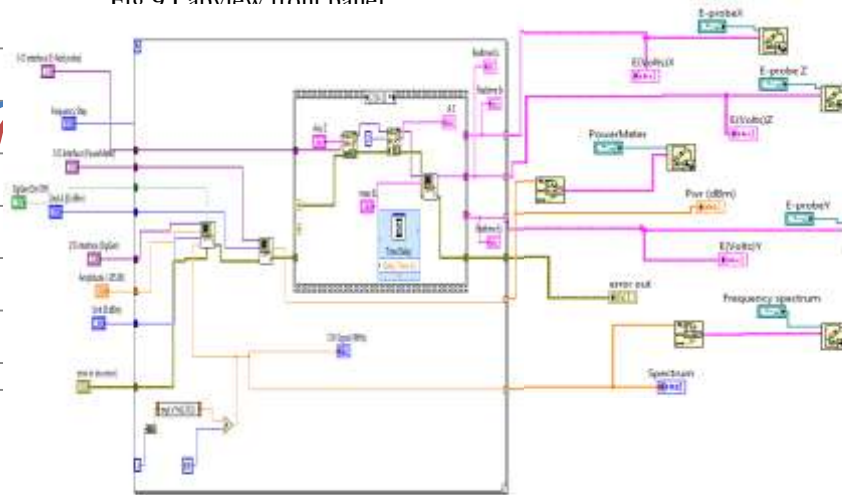

Fig.10 Block of Labview code

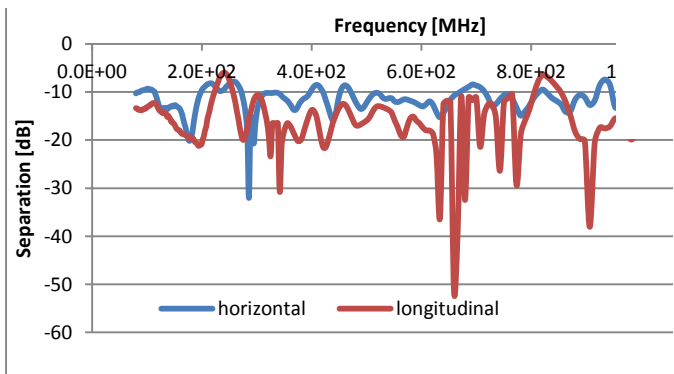

Fig.8d position 4

### CONCLUSION

The electric field distribution in an empty (unloaded) GTEM cell provides insight into other reasons for lack of homogeneity in field distribution. If there is a considerable electric field in the transverse and longitudinal direction it will then mean part of the energy of TEM is lost in these directions. This is also an indication that higher modes are present. Choice of the working volume is a critical factor in having repeatability and reproducibility in GTEM cells. As can be seen from the plots of the primary and secondary fields, there is sufficient separation to allow for both radiated and susceptibility measurements as required by IEC 61000-4-20 standard.

#### ACKNOWLEDGMENT

The author wishes to express his deep appreciation to the George Green Institute of Electromagnetic Research (GGIEMR) for the facilities used and the TETFUND/NDA, Kaduna for sponsorship.

#### REFERENCES

- [1] Hansen, P. Wilson, D. Konigstein, H. Schaer, "A broadband alternative EMC test chamber based on a TEM-cell anechoic-chamber hybrid concept", *Proceedings of the 1989 Int. Symp. on EMC*, Nagoya, Japan, September 1989, p. 133-137.
- [2] John Osburn, "New Test Cell Offers Both Susceptibility And Radiated and Emission Capabilities", *R. F. Design*, August 1990, pp.39-41.
- [3] E. L. Bronaugh, J.D.M. Osburn, "Radiated emissions test performance of the GHz TEM cell", *IEEE International Symposium on Electromagnetic Compatibility*, 1991, 12-16 Aug.1991, Page(s): 1-7.
- [4] Kai Haake and Jan Luiken ter Haseborg "Precise investigation of field homogeneity inside a GTEM cell' 2008 IEEE
- [5] The GTEM concept. GTEM test cells ETS.Lindgren-An ESCO Technologies Company Texas, USA [www.ets-lindgren.com](http://www.ets-lindgren.com)
- [6] Azian Ubin and Mohd Jenu "Characterization of electric field in a GTEM cell" RF and Microwave conference, Subang, Selangor, Malaysia IEEE 2004
- [7] Pande, D.C and Bhatt, P.K. "Characterization of gigahertz transverse electromagnetic cell (GTEM cell), in proceedings of the International Conference on electromagnetic Interference and Compatibility, 1999.
- [8] IEC 61000-4-20 Electromagnetic Compatibility (EMC) – Part 4: Testing and measurement techniques. Section 20: emission and Immunity Testing in Transverse Electromagnetic (TEM) waveguides. International electro-technical commission, Geneva, Switzerland, Draft 2CD 61000-4-20, 2001.
- [9] A. Nothofer and M.J. Alexander, D. Bozec, L. McCormack and A.C. Marvin, "A good practice guide-the use of GTEM cells for EMC measurements applying IEC 61000-4-20." National Physical Laboratory, Teddington, Middlesex, UK, [www.npl.co.uk](http://www.npl.co.uk)