

Analysing Performance of Companding Technique For PAPR Reduction in OFDM System

Rikhee Ram¹, Manoj Gabhel²

¹M.Tech, Dr. C.V. Ranam Institute Of Science and Technology,
Bilaspur (C.G)
ramriki@rediffmail.com

²M.Tech, Dr. C.V. Ranam Institute Of Science and Technology,
Bilaspur (C.G)
manoj.gabhel555@gmail.com

Abstract: *The major drawback of OFDM transmission is the large envelope fluctuation which is qualified as Peak to Average Power Ratio. Since power amplifier is used at the transmitter, so as to operate in a perfectly linear region the operating power lies below the available power. For reduction of this PAPR lot of algorithms have been developed. A uniformly distributed nonlinear companding scheme efficiently reduces PAPR with a low Bit Error Rate (BER). However, the uniformly distributed companding scheme cannot perform variably to satisfy the different performance requirements for the systems. Therefore, this work proposes a novel scheme that transforms the OFDM signals into a trapezium distribution. The uniformly distributed companding scheme is a special case of the proposed scheme. The general formulas of the proposed scheme are derived and the trade-off between PAPR reduction and BER performance is achieved by setting the value of a parameter. Then, the simulation results show the PAPR reduction and the BER over the AWGN and multipath channels, indicating that the proposed scheme provides a favourable trade-off between the Papr Reduction and the BER.*

Keywords: Companding, OFDM, PAPR.

1. Introduction

ORTHOGONAL frequency division multiplexing (OFDM) systems have been extensively applied in wireless communication systems, e.g. Worldwide Interoperability for Microwave Access (WiMAX). OFDM systems have one major disadvantage, i.e. a very high Peak-to-Average Power Ratio (PAPR) at the transmitter [1]. When the OFDM signals with high PAPR are transmitted through a nonlinear device, such as a high-power amplifier (HPA) or a digital-to-analog converter (DAC), a high peak signal generates out-of-band energy and in-band distortion. These degradations would seriously affect the performance of OFDM systems. In order to reduce the PAPR of OFDM systems, methods [2]–[11] have been studied for a few years. They fall into two categories [2]. The first category of the PAPR reduction schemes changes the formation of the OFDM signals with high PAPR before multicarrier modulation, e.g. coding, selective mapping (SLM), and partial transmit sequence (PTS). The researches [4]–[6] reduce the computational complexity for the SLM scheme. The authors in [7] reduce the computational complexity for the PTS scheme. The researches [4]–[7] maintain the original BER of OFDM systems but require a large number of computational complexity and side information.

The second category of the PAPR reduction schemes transforms the OFDM signals after multicarrier modulation, such as companding techniques [8]–[13]. The μ -law companding scheme [8] is a common companding scheme. Then, the other companding scheme [9] utilizes a nonlinear operation to

transform the original OFDM signals into the uniform distribution and efficiently reduce PAPR with a low Bit Error Rate (BER). Similarly, the exponential companding scheme [10] transforms the amplitude of the original OFDM signals into the uniform distribution. The referred uniformly distributed companding schemes [9], [10] can keep the same average power as that of the original signal and significantly outperform the μ -law companding scheme [8]. Furthermore, the piecewise nonlinear companding scheme [11] has been also proposed to compare with the exponential companding scheme [10], i.e. one uniformly distributed uniformly-distributed scheme [9]. The research [12] offers a trade-off between BER performance and PAPR reduction by adjusting two parameters, and its companding function is a piecewise function with three pieces. Thus, the companding function of the research [12] is more complicated than those of the others [8]–[11]. Two nonlinear companding schemes with iterative receiver are proposed in [13] and also outperform the μ -law companding scheme [8]. However, the reference [13] requires additional FFT and IFFT devices. The investigations [8]–[13] offer efficient PAPR reduction but get a little worse BER without side information. Although the uniformly-distributed scheme [9] can offer the efficient PAPR reduction with low BER, it can not fulfill the performance requirements for various systems. Therefore, this work proposes a nonlinear companding scheme to transform the original OFDM signals into the trapezium distribution by regulating a parameter that governs the proposed trapezium distribution, and the companding function is a continuous function. The case of the

uniform distribution is a special case of the proposed scheme. Then, the general formulas of the attenuation factor caused by the nonlinear operation and the theoretical complementary cumulative distribution function (CCDF) of PAPR for the proposed scheme are derived. The performance of the proposed scheme is simulated and compared with those of the uniformly-distributed scheme [9] and the piecewise nonlinear companding scheme [11], while the different modulation schemes and the AWGN or multipath channel are considered. The remainder of this paper is organized as follows. Section II introduces the PAPR problem of the OFDM system and the uniformly distributed companding scheme [9]. Section III shows the derivation of the general formulas for the proposed scheme, and then the attenuation factor caused by the nonlinear operation is derived for the proposed scheme. Section IV shows the theoretical analysis of the CCDF of the PAPR for the proposed scheme and the simulation results of the CCDF of the PAPR.

2. OFDM Transmission Scheme

Orthogonal frequency division multiplexing (OFDM) transmission scheme is a type of multichannel system which avoids the usages of the oscillators and band limited filters for each subchannel. The OFDM technology was first conceptualized in the 1960s and 1970s. The main idea behind the OFDM is that since low-rate modulations are less sensitive to multipath, the better way is to send a number of low rate streams in parallel than sending one high rate waveform. It divides the frequency spectrum into sub-bands small enough so that the channel effects are constant (flat) over a given sub-band. Then a classical IQ (In phase Quadrature phase) modulation (BPSK, QPSK, M-QAM, etc) is sent over the sub-band. If it designed correctly, all the fast changing effects of the channel disappear as they are now occurring during the transmission of a single symbol and are thus treated as flat fading at the receiver. A large number of closely spaced orthogonal subcarriers are used to carry data. The data is divided into several parallel data streams or channels, one for each subcarrier. Each subcarrier is modulated with a conventional modulation scheme such as Quadrature Amplitude Modulation (QAM) or Phase Shift Keying (PSK) at a low symbol rate. The total data rate is to be maintained similar to that of the conventional single carrier modulation scheme with the same bandwidth. Orthogonal Frequency Division Multiplexing (OFDM) is a promising technique for achieving high data rate and combating multipath fading in Wireless Communications. Orthogonal Frequency Division Multiplexing is a special form of multicarrier modulation which is particularly suited for transmission over a dispersive channel. The orthogonality of the carriers means that each carrier has an integer number of cycles over a symbol period. Due to this integer number of cycles, the spectrum of each carrier has a null at the center frequency of each of the other carriers in the system that results in no interference between the carriers, allowing them to be spaced as close as possible. The problem of overhead carrier spacing required in Frequency Division Multiplexing (FDM) can be recovered. So this multicarrier transmission scheme allows the overlapping of the spectra of subcarriers for bandwidth efficiency. The OFDM transmission scheme is being shown in the figure

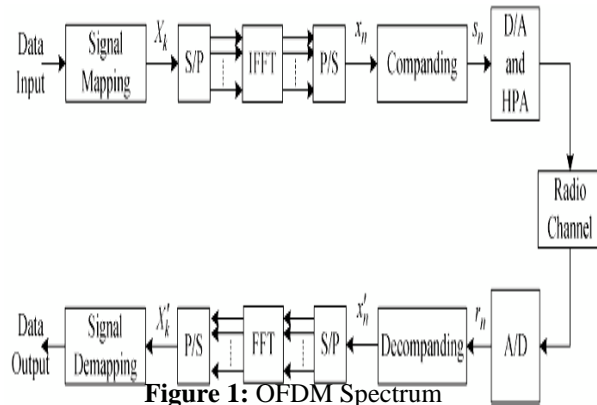

Figure 1: OFDM Spectrum

3. Peak – To- Average Power Ratio

Presence of large number of independently modulated sub-carriers in an OFDM system the peak value of the system can be very high as compared to the average of the whole system. This ratio of the peak to average power value is termed as Peak-to Average Power Ratio. Coherent addition of N signals of same phase produces a peak which is N times the average signal.

The major disadvantages of a high PAPR are;

- Increased complexity in the analog to digital and digital to analog converter
- Reduction in efficiency of RF amplifiers.

3.1 PAPR Of A Multicarrier Signal

Let the data block of length N be represented by a vector $\mathbf{X} = [X_0, X_1, \dots, X_{N-1}]^T$. Duration of any symbol X_k in the set \mathbf{X} is T and represents one of the sub-carriers $\{f_n, n = 0, 1, \dots, N-1\}$ set. As the N sub-carriers chosen to transmit the signal are orthogonal to each other, so we can have $f_n = n\Delta f$ where $n\Delta f = 1/NT$ and NT is the duration of the OFDM data block X. The complex data block for the OFDM signal to be transmitted is given by

$$x(t) = \frac{1}{\sqrt{N}} \sum_{n=0}^{N-1} X_n \cdot e^{j2\pi n\Delta f t}, \quad 0 \leq t \leq NT,$$

The PAPR of the transmitted signal is defined as

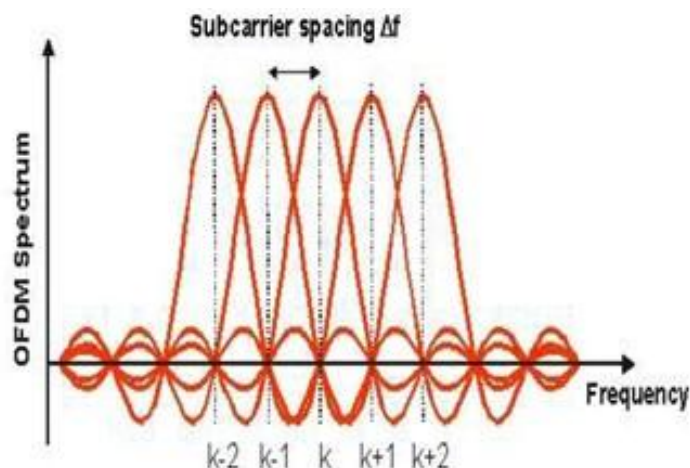

Fig 2: OFDM system using Companding Technique

$$PAPR = \frac{\max_{0 \leq t < NT} |x(t)|^2}{1/NT \int_0^{NT} |x(t)|^2 dt}$$

Reducing the $\max|x(t)|$ is the principle goal of PAPR reduction techniques. Since, discrete-time signals are dealt with in most systems, many PAPR techniques are implemented to deal with amplitudes of various samples of $x(t)$. Due to symbol spaced output in the first equation we find some of the peaks missing which can be compensated by oversampling the equation by some factor to give the true PAPR value

3.2 OFDM system using companding techniques

Orthogonal Frequency Division Multiplexing (OFDM) has become the most widely adopted technology in wireless communication systems. OFDM is limited mainly by its high Peak-to-Average Power Ratio (PAPR). A uniformly distributed nonlinear companding scheme efficiently reduces PAPR with a low Bit Error Rate (BER). However, the uniformly distributed companding scheme cannot perform variably to satisfy the different performance requirements for the system.

3.3 PAPR Reduction Techniques

PAPR reduction techniques vary according to the needs of the system and are dependent on various factors. PAPR reduction capacity, increase in power in transmit signal, loss in data rate, complexity of computation and increase in the bit-error rate at the receiver end are various factors which are taken into account before adopting a PAPR reduction technique of the system. The PAPR reduction techniques on which we would work upon and compare in our later stages are as follows:

1. Amplitude Clipping And Filtering:

A threshold value of the amplitude is set in this process and any sub-carrier having amplitude more than that value is clipped or that sub-carrier is filtered to bring out a lower PAPR value.

2. SELECTED MAPPING

In this a set of sufficiently different data blocks representing the information same as the original data blocks are selected. Selection of data blocks with low PAPR value makes it suitable for transmission.

3. PARTIAL TRANSMIT SEQUENCE

Transmitting only part of data of varying sub-carrier which covers all the information to be sent in the signal as a whole is called Partial Transmit Sequence Technique.

4. COMPANDING TECHNIQUE

Orthogonal frequency division multiplexing (OFDM) transmission scheme is a type of multichannel system which avoids the usages of the oscillators and bandlimited filters for each subchannel. The OFDM technology was first conceptualized in the 1960s and 1970s. The main idea behind the OFDM is that since low-rate modulations are less sensitive to multipath, the better way is to send a number of low rate streams in parallel than sending one high rate waveform. It divides the frequency spectrum into sub-bands small enough so that the channel effects are constant (flat) over a given sub-band. Then a classical IQ (In phase Quadrature phase) modulation (BPSK, QPSK, M-QAM, etc) is sent over the sub-band. If it designed correctly, all the fast changing effects of the channel disappear as they are now occurring during the transmission of a single symbol and are thus treated as flat fading at the receiver. A large number of closely spaced orthogonal subcarriers are used to carry data. The second category of the PAPR reduction schemes transforms the OFDM signals after multicarrier modulation, such as companding techniques [8]–[13]. The μ -law companding scheme [8] is a common companding scheme. Then, the other companding scheme [9] utilizes a nonlinear operation to transform the original OFDM signals into the uniform distribution and efficiently reduce PAPR with a low Bit Error Rate (BER). Similarly, the exponential companding scheme [10] transforms the amplitude of the original OFDM signals into the uniform distribution. The referred uniformly distributed companding schemes [9], [10] can keep the same average power as that of the original signal and significantly outperform the μ -law companding scheme [8]. This subsection derives the generic formulas of the new scheme, whose companding function is defined by an inverse hyperbolic sine function with an inflexion point. Using this approach, the amplitude or power of the transmitted signal can be reallocated more reasonably and flexibly.

4. Simulation And Result

In this simulation, the PAPR Reduction and BER Performance of the proposed scheme with the exponential companding scheme using the AWGN channels are considered.

The parameter taken for simple OFDM is as Follow:-

Bits/carrier = 1000

Orthogonal carrier = 4

Snr = 0 to 10 db

Compander parameter = σ_1 , μ 0.

Figure 3 : Simulated BER for Simple OFDM under AWGN Channel.

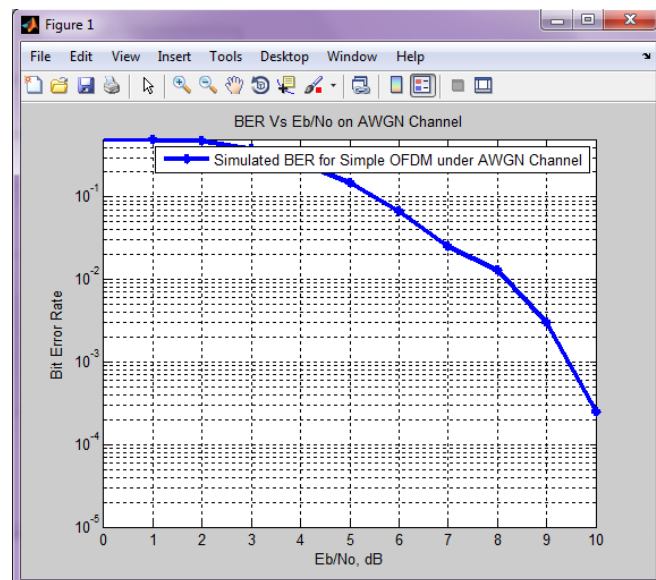

So it is very much clear that when we are using Companding technique the performance of BER in the channel is increases and simultaneously the value of PAPR is reduces with less Average power requirement

Figure 4 : Received Sub-carriers Power

From the Figure 3 It is clear that for simple OFDM i.e. without compander the BER is near about 10^{-2} and the received sub-carrier power is so much fluctuated it is vary from 0.2 to 1.

The value of PAPR is 2.09 and average power is 0.49.

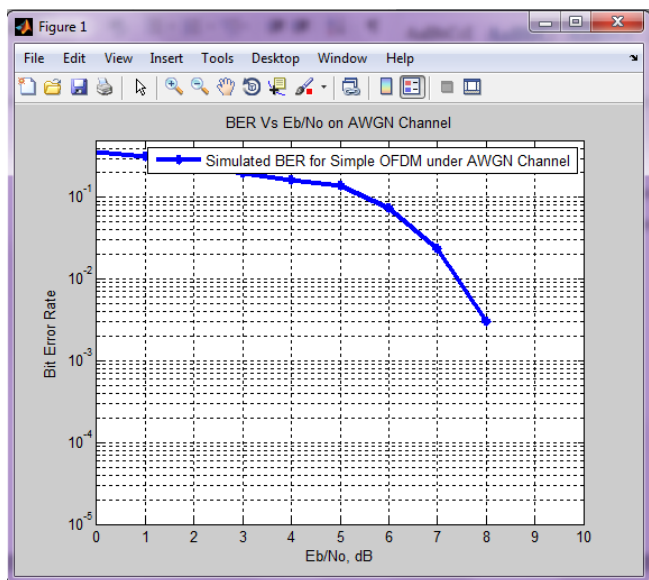

For SNR 0 to 10 db.

Figure 5 Simulated BER for Compander OFDM under AWGN Channel

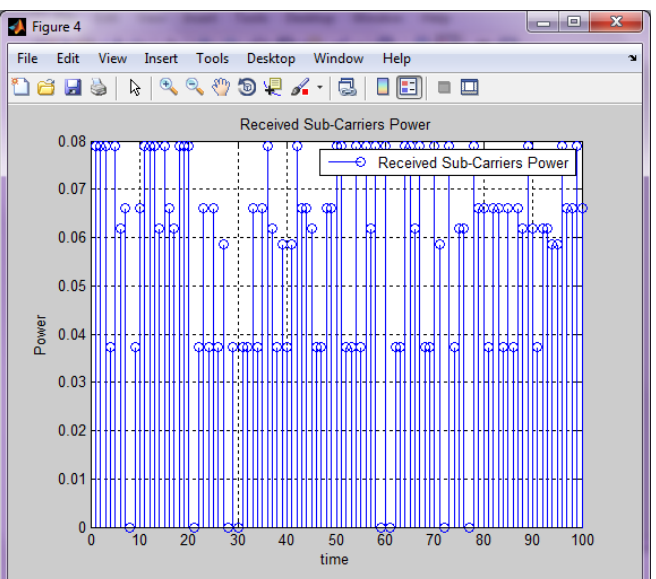

5. Conclusion

From figure (3 to 6) it is clear that the OFDM with Compander technique has better BER. Companding techniques can solve the high PAPR problem for OFDM systems. Two of companding scheme, i.e. the uniformly distributed companding scheme and the piecewise companding scheme, are studied herein to provide efficient PAPR reduction with a low BER. However, both of the referred schemes cannot deliver the performance that satisfies the various requirements of the systems. In this work, the distribution of the OFDM signal is transformed into the trapezium distribution, and the general formulas for the proposed scheme are derived that enable the desired performance to be achieved by controlling the parameter. The uniformly-distributed companding scheme is the special case of the proposed scheme. Then, the simulation results reveal that the proposed scheme may offer the more efficient PAPR reduction or the lower BER than the uniformly- distributed and piecewise schemes under the condition of efficient PAPR reduction or efficient BER performance

Reference

Figure 6 : Received Sub-carriers Power

From the Figure 5 It is clear that for simple OFDM i.e. with compander the BER is near about 10^{-4} and the received sub-carrier power is not so much fluctuated it is vary from 0.04 to 0.08.

The value of PAPR is 1.43 and average power is 0.055.

For SNR 0 to 10 db.

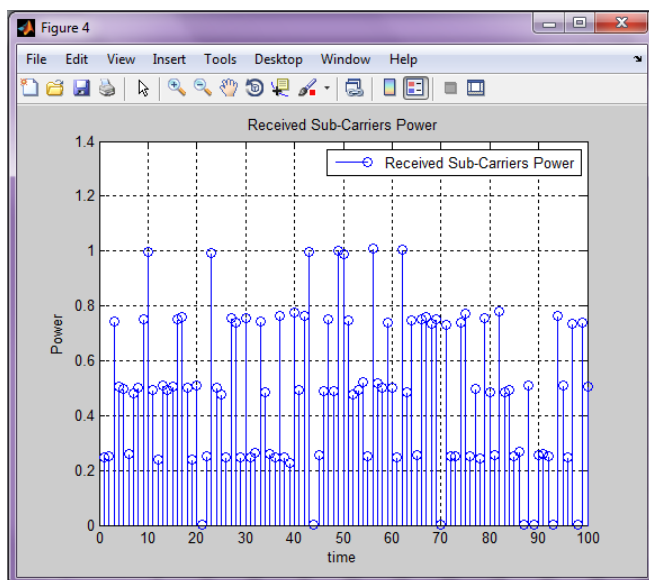

- [1] J. Tellado, "Multicarrier transmission with low PAR," Ph.D. dissertation, Stanford Univ., Stanford, CA, 1998.
- [2] S. H. Han and J. H. Lee, "An overview of peak-to-average power ratio reduction techniques for multicarrier transmission," *IEEE Wireless Commun.*, vol. 12, pp. 56–65, Apr. 2005.
- [3] T. Jiang and Y. Wu, "An overview: Peak-to-average power ratio reduction techniques for OFDM signals," *IEEE Trans. Broadcast.*, vol. 54, no. 2, pp. 257–268, Jun. 2008.
- [4] C. P. Li, S. H. Wang, and C. L. Wang, "Novel low-complexity SLM schemes for PAPR reduction in OFDM systems," *IEEE Trans. Signal Process.*, vol. 58, no. 5, pp. 2916–2921, May 2010.
- [5] J. H. Wen, S. H. Lee, and C. C. Kung, "SLM-based data position permutation method for PAPR reduction in OFDM system", in *wireless communication and mobile computing*. Hoboken, NJ: wiley Inter science, 2008
- [6] S. H. Wang and C. P. Li, "A low-complexity PAPR reduction scheme for SFBC MIMO-OFDM systems," *IEEE Signal Process. Lett.*, vol. 16, no. 11, pp. 941–944, Nov. 2009.
- [7] N. T. Hieu, S. W. Kim, and H. G. Ryu, "PAPR reduction of the low complexity phase weighting method in OFDM communication system," *IEEE Trans. Consum. Electron.*, vol. 51, no. 3, pp. 776–782, Aug. 2005.
- [8] X. B. Wang, T. T. Tjhung, and C. S. Ng, "Reduction of peak-to-average power ratio of OFDM system using a companding technique", *IEEE Trans. Broadcast.*, Vol.45 no.3, pp. 303-307, sep 1999.
- [9] T. Jaing W. Xiang, P. C. Richardson, D. Qu and G. zhu, "On the nonlinear companding transform for reduction in PAPR of MCM," *IEEE Trans. Wireless Commun.*, vol. 6, no. 6, pp. 2017–2021, Jun. 2007.
- [10] T. Jiang, Y. Yang, and Y. Song, "Exponential companding transform for PAPR reduction in OFDM system", *IEEE Trans. Broadcast.*, vol. 51, no. 2, pp. 244-248 june 2005.
- [11] J. Hou, J. Ge, D. Zhai, and J. Li, "Peak-to-average power ratio reduction of OFDM signals with nonlinear companding . scheme," *IEEE Trans. Broadcast.*, vol. 56, pp. 1349-1351, Dec. 2009.
- [12] J. Hou, J. H. Ge, and J. Li, "Trapezoidal companding scheme for peak-to-average power ratio reduction of OFDM signals," *Electron. Lett.*, vol. 45, no. 25, pp. 1349–1351, Dec. 2009.
- [13] T. Jiang, W. Yao, P. Guo, Y. Song, and D. Qu, "Two novel nonlinear companding schemes with iterative receiver to reduce PAPR in multicarrier modulation system." *IEEE Trans. Broadcast.*, vol. 51, no.2, pp. 268-273. Jun 2006.
- [14] D. Dardari, V. Tralli, and A. Vaccari, "A theoretical characterization of nonlinear distortion effects in OFDM system," *IEEE Trans. Commun.*, vol. 48, no. 10, pp. 1755-1764, Oct. 2000.
- [15] P. Banelli and S. Caopardi, "Theoretical analysis and performance of OFDM signals in nonlinear AWGN channels," *IEEE Trans. Commun.*, vol. 48, pp. 430–441, march 2000.
- [16] J. G. Andrews, A. Ghosh, and R. Muhamed, *Fundamentals of WiMAX: Understanding Broadband Wireless Networking*. Englewood Cliffs, NJ: Prentice hall 2007.
- [17] C. Oestges and B. Clerckx, *MIIMO Wireless Communications: From Real-World Propagation to Space-Time Code Design*. San Diego, CA: Academic Press, 2007, pp. 409–410.
- [18] E. Costa, M. Midrio, and S. Pupolin, "Impact of amplifier nonlinearities on ofdm transmission system Performance," *IEEE Trans. Commun.*, vol. 3, pp. 37–39 feb. 1999.
- [19] Conti, D. Dardari, and V. Tralli, "On the performance of cdma systems with nonlinear amplifier and awgn," in *Proc. 6th IEEE Int. Symp. Spread Spectrum Techniques and Applications (ISSSTA)*, Sep. 2000, vol. 1, pp. 197–202.

Author Profile

Rikhee Ram received M.Tech (2012-14) from the department of Electronic & Communication Engineering Specialization in Digital Communication at Dr C.V.R.U. Bilaspur (C.G). His Area of Interest includes Communication System...

Manoj Gabhel received M.Tech (2012-14) from the department of Electronic & Communication Engineering Specialization in Digital Communication at Dr C.V.R.U. Bilaspur (C.G). He had done PG Diploma in Industrial Automation System Design From NIELIT Calicut Kerala India in 2009. His Area of Interest includes Communication System...