

# Fuzzy Logic Enforced Traffic Management for High Speed Networks

*T. Hari<sup>1</sup>, P. Hemanth Kumar<sup>2</sup>*

<sup>1</sup>M.Tech Student, Department of CSE,  
KMM College of Engineering, Tirupati  
*hari.1244@gmail.com*

<sup>2</sup>Assistant Professor, Department of CSE,  
KMM College of Engineering, Tirupati  
*hemanthmtechcse@gmail.com*

**Abstract:** *As the increase in use of computing devices such as computers, tablets and smart phones there is a huge demand for the fast-growing internet traffic. Distributed traffic management frame work has been proposed, in which routers are deployed with intelligent data rate controllers to tackle the high traffic level. The traffic control protocol is unique as other traffic control protocols have to estimate network parameters which involves link latency, bottleneck bandwidth, packet loss rate, or the number of flows in order to compute the allowed source sending rate. The fuzzy-logic based controller can measure queue size directly; it neglects various potential performance issues arising due to parameter estimations as we reduce much consumption of computation and memory resource in routers. As a network parameter, the queue size can be monitored accurately and used for making proactive decision if action should be taken to regulate the source sending rate, and thus increases the resilience of the network to traffic congestion. By the fuzzy logic technique, QoS (Quality of Service) in communication is assured by good performances of our scheme such as max-min fairness, low queuing delay and good robustness to network dynamics. The conclusion is that the results and comparisons have verified the effectiveness and made a created a new benchmark that our traffic management scheme using fuzzy-logic can achieve better performance than the existing protocols that depend entirely on the estimation of network parameter.*

**Keywords:** Congestion control, fuzzy logic control, quality of service, max-min fairness, robustness, traffic management.

## 1. Introduction

Network traffic management can prevent a network from severe congestion and degradation in throughput delay performance. Traffic congestion control is one of the effective approaches to manage the network traffic [1], [2]. Historically, TCP (Transmission Control Protocol) Reno [3], [4] is a widely deployed congestion control protocol that tackles the Internet traffic. It has the important feature that the network is treated as a black box and the source adjusts its window size based on packet loss signal [5]. However, as an implicit control protocol, TCP encounters various performance problems (e.g., utilization, fairness and stability) when the Internet BDP

(Bandwidth-Delay Product) continues to increase. These have been widely investigated with various proposed solutions such as the AQM (Active Queue Management) schemes [6]–[10] whose control protocols are also implicit in nature. As an alternative, a class of explicit congestion control protocols has been proposed to signal network traffic level more precisely by using multiple bits. Examples are the XCP [6], RCP [11], JetMax [12] and MaxNet [13]. These protocols have their controllers reside in routers and directly feed link information back to sources so that the link bandwidth could be efficiently utilized with good scalability and stability in high BDP networks. Specifically, JetMax and MaxNet signal network

congestion by providing the required fair rate or the maximum link price, and then the final sending rate is decided by sources according to some demand functions or utility functions. XCP feeds back the required increment or decrement of the sending rate, while RCP directly signals sources with the admissible sending rate according to which sources pace their throughput. The advantages of these router-assisted protocols are that 1) they can explicitly signal link traffic levels without maintaining per-flow state, and 2) the sources can converge their sending rates to some social optimum and achieve a certain optimization objective [12]. However, most of these explicit congestion control protocols have to estimate the bottleneck bandwidth in order to compute the allowed source sending rate or link price. Recent studies show that misestimating of link bandwidth (e.g., in link sharing networks or wireless networks) may easily occur and can cause significant fairness and stability problems [14], [15]. There are some latest protocols on wireless applications such as QFCP (Quick Flow Control Protocol) [16] and the three protocols called Blind, Errors' and MAC [17]. They have improved on the estimation error while having high link utilization and fair throughput. However, they still have the fundamental problem of inaccurate estimation resulting in performance degradation. In addition, their bandwidth probing speed may be too slow when the bandwidth jumps a lot. Also, they cannot keep the queue size stable due to Oscillations, which in turn affects the stability of their sending rates. The contributions of our work lie in: 1) using fuzzy logic theory to design an explicit rate-based traffic management scheme (called the Intel Rate controller) for the high-speed IP networks; 2) the application of such a fuzzy logic controller using less performance parameters while providing better performances than the existing explicit traffic control protocols; 3) the design of a Fuzzy Smoother mechanism that can generate relatively smooth flow throughput; 4) the capability of our algorithm to provide max-min fairness even under large network dynamics that usually render many existing controllers unstable.

For the remainder of the paper, the following notations and symbols pertain.

- A Edge value of MFs (Membership Functions) of  $e(t)$ , beyond which the MFs of  $e(t)$  saturate
- B Buffer capacity
- $c(t)$  Service rate (output link capacity) of a router

- C Edge value of MFs of  $g(e(t))$ , beyond which the MFs of  $g(e(t))$  saturate
- D Outermost edge value of MFs of  $u(t)$
- $e(t)$  Queue error which is one input of the IntelRate controller
- $g(e(t))$  Integration of  $e(t)$  which is the other input of the IntelRate controller
- $m$  Multiple of TBO to design the width limit for the MFs of input  $e(t)$  and  $g(e(t))$
- N Number of LVs (Linguistic Values)
- $q_0$  TBO of a router
- $q(t)$  IQSize (Instantaneous Queue Size) of a router
- $u(t)$  The controller crisp output for each flow
- $u'(t)$  Current source sending rate
- $v(t)$  Aggregate uncontrolled incoming traffic rate to a router
- $y(t)$  Aggregate controlled incoming traffic rate to a router (also aggregate controller output)
- $\mu P_j$  Input fuzzy set of the IntelRate controller
- $\mu U_j$  Output fuzzy set of the IntelRate controller
- $\tau_{fi1}$  Time delay of a packet from source  $i$  to a router
- $\tau_{fi2}$  Time delay of a packet from a router to its destination  $i$
- $\tau_{bi}$  Feedback delay of a packet from destination  $i$  back to source  $i$
- $\tau_{pi}$  RTPD (Round Trip Propagation Delay)
- $\tau_i$  RTT (Round Trip Time)

## 2. TRAFFIC MANAGEMENT PRINCIPLE AND MODELING

We consider a backbone network interconnected by a number of geographically distributed routers, in which hosts are attached to the access routers which cooperate with the core routers to enable end-to-end communications. Congestion occurs when many flows traverse a router and because it's IQSize (Instantaneous Queue Size) to exceed the buffer capacity, thus making it a bottleneck in the Internet. Since any router may become bottleneck along an end-to-end data path, we would like each router to be able to manage its traffic.

Below is the general operation principle of our new traffic management/control algorithm. Inside each router, our distributed traffic controller acts as a data rate regulator by measuring and monitoring the IQSize. As per its application,

every host (source) requests a sending rate it desires by depositing a value into a dedicated field Req\_rate inside the packet header. This field can be updated by any router en route. Specifically, each router along the data path will compute an allowed source transmission rate according to the IQSize and then compare it with the rate already recorded in Req\_rate field. If the former is smaller than the latter, the Req\_rate field in the packet header will be updated; otherwise it remains unchanged. After the packet arrives at the destination, the value of the Req\_rate field reflects the allowed data rate from the most congested router along the path if the value is not more than the desired rate of the source. The receiver then sends this value back to the source via an ACK (Acknowledgment) packet, and the source would update its current sending rate accordingly. If no router modifies Req\_rate field, it means that all routers en route allow the source to send its data with the requested desired rate.

In order to implement our new controller in each router, we model a typical AQM router in Figure 1 with M sources sending their Internet traffic to their respective destinations. For  $i = 1, 2, \dots, M$ ,  $u_i(t)$  is the current sending rate of source  $i$ ;  $u_i(t)$  is the sending rate of source  $i$  determined by the routers along the end-to-end path;  $y(t)$  is the incoming aggregate controlled flow rate;  $v(t)$  is the incoming aggregate uncontrolled flow rate, and  $c(t)$  is the link bandwidth (measured in bps). For a particular source-destination pair  $i$ ,  $\tau_{fi1}$  is the time delay of a packet from source  $i$  to the router, and  $\tau_{fi2}$  is the time delay of the packet of source  $i$  from the router to the destination  $i$ , while  $\tau_{bi}$  is the feedback delay from destination  $i$  back to source  $i$ . Obviously,  $\tau_{pi} = \tau_{fi1} + \tau_{fi2} + \tau_{bi}$  is the RTPD (Round Trip Propagation Delay). Considering other delays en route (e.g., queueing delay), source  $i$  may update its current rate  $u_i(t)$  according to the  $u_i(t)$  when the ACK packet arrives after one RTT (Round Trip Time)  $\tau_i$ .

Considering the possible dynamics of both incoming traffic and link bandwidth in the router in Figure 1, we model the bottleneck link with a queue in which both the controlled arrival rate  $y(t)$  and the service rate  $c(t)$  may vary with respect to time. Let  $q(t)$  be the router IQSize. The variations in  $y(t)$  and/or  $c(t)$  can cause changes in the queue size of a router, as expressed in the following differential equation.

$$q(t) = y(t) + v(t) - c(t) \quad q(t) > 0$$

$$[y(t) + v(t) - c(t)] + q(t) = 0$$

where  $[x]^+ = \max(0, x)$ .

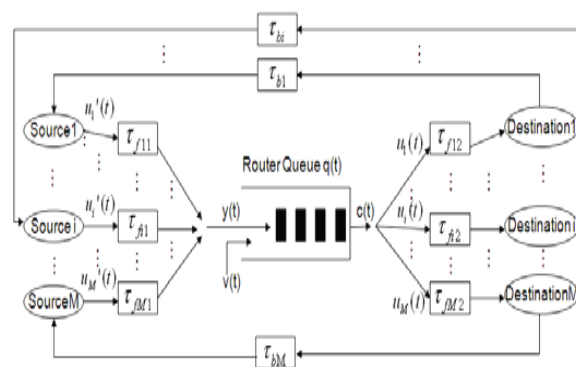

Figure 1: System Model of an AQM router

### 3. The IntelRate Controller Design

Figure 2 depicts the components of our fuzzy logic traffic controller for controlling traffic in the network system defined in Fig. 1. Called the IntelRate, it is a TISO (Two-Input Single-Output) controller. The TBO (Target Buffer Occupancy)  $q_0 > 0$  is the queue size level we aim to achieve upon congestion.

The queue deviation  $e(t) = q_0 - q(t)$  is one of the two inputs of the controller. In order to remove the steady state error, we choose the integration of  $e(t)$  as the other input of the controller, i.e.  $g(e(t)) = e(t) dt$ . The aggregate output is  $y(t) = u_i(t - \tau_i)$ . Under heavy traffic situations, the IntelRate controller would compute an allowed sending rate  $u_i(t)$  for flow  $i$  according to the current IQSize so that  $q(t)$  can be stabilized around  $q_0$ . In our design, IQSize  $q(t)$  is the only parameter each router needs to measure in order to complete the closed-loop control.

FLC is a non-linear mapping of inputs into outputs, which consists of four steps, i.e., rule base building, fuzzification, inference and defuzzification. The concepts of fuzzy set and logic of FLC were introduced in 1965 by Zadeh, and it was basically extended from two-valued logic to the continuous interval by adding the intermediate values between absolute TRUE and FALSE.

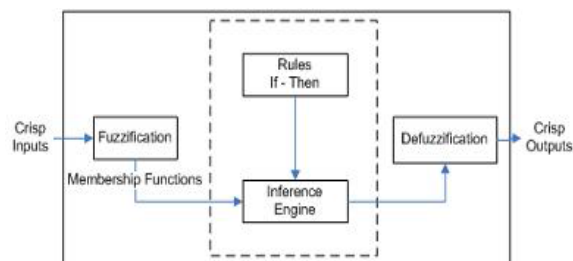

Figure 2: The IntelRate closed-loop control system

## 4. Performance Evaluation

The capability of the IntelRate controller is demonstrated by performance evaluations through a series of experiments. We will first describe the simulated network and performance measures of a case study in Section A. Section B demonstrate the system robustness upon large network changes.

Queuing jitter control and the effect of short-lived traffic will be discussed in Sections C and D. Section E evaluates the bandwidth utilization and packet loss rate of the IntelRate controller. Finally, Section F discusses the choices of some design parameters.

For the following evaluation, we choose  $N = 9$ ,  $m = 8$  and the delay of  $TBO \leq 10ms$ , while  $B = 10 * q_0$  and  $d = 50ms$  using the design principles for the IntelRate controller discussed in Section III. As noted there, some of these “optimum/good” values are the results after many experiments on different combinations. Due to space limitation, they are not presented.

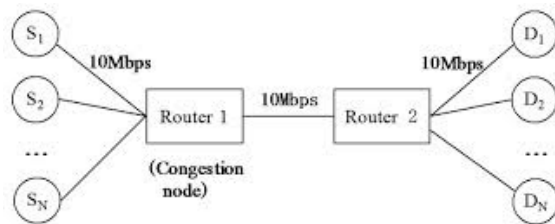

**Figure 3:** Simulated Network

The single bottleneck network in Fig. 3 is used to investigate the controller behavior of the most congested router. We choose Router 1 as the only bottleneck in the network, whereas Router 2 is configured to have sufficiently high service rate and big buffer  $B$  so that congestion never happens there. The numbers in Fig. 3 are the IDs of the subnets/groups attached to each router. Their configuration is summarized in Table II, in which there are  $M = 11$  subnet pairs, which form the source destination data flows in the network, and they run various Internet applications such as the long-lived ftp, short-lived http, or the unresponsive UDP-like flows (also called uncontrolled ftp flows). Since the link bandwidths we want to simulate have a magnitude of Giga bits per second, we need to use 20 flows in each subnet to generate enough traffic to produce congestion. All flows within each group have the same RTPD and behavior, but different from the flows of other groups. The RTPD includes the forward path propagation delay and the feedback propagation delay, but

does not include the queuing delay, which may vary according to our settings of TBO size in the experiments. The reverse traffic is generated by the destinations when they piggyback the ACK information back to the sources.

The TBO and the buffer capacity  $B$  in Router 1 in each experiment are set according to the approaches discussed in Section III. We also adopt some typical values from the experiments of existing works so that we can make our experiments more meaningful. In particular, all the ftp packets have the same size of 1024 bytes [19] while the http packet size is uniformly distributed in the range of [800, 1300] bytes.

**Table 1: Sources Characters**

Subnet ID	Source ID	Flow NO.	RTPD(ms)
ftp group 1	1-20	ftp 1-20	80
ftp group 2	21-40	ftp 21-40	120
ftp group 3	41-60	ftp 41-60	160
ftp group 4	61-80	ftp 61-80	200
ftp group 5	81-100	ftp 81-100	240
http group 1	101-120	http 1-20	80
http group 2	120-140	http 21-40	120
http group 3	141-160	http 41-60	160
http group 4	161-180	http 61-80	200
http group 5	181-200	http 81-100	240
uncontrolled ftp	201	UDP 1	160

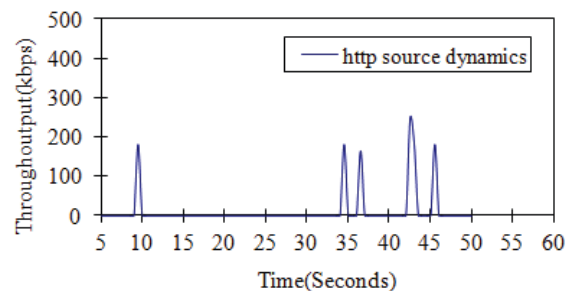

**Figure 4:** HTTP Sessions's example

## 5. Conclusion

A novel traffic management scheme, called the IntelRate controller, has been proposed to manage the Internet congestion in order to assure the quality of service for different service applications. The controller is designed by paying attention to the disadvantages as well as the advantages of the existing congestion control protocols. As a distributed operation in networks, the IntelRate controller uses the instantaneous queue size alone to effectively throttle the source sending rate with max-min fairness. Unlike the existing explicit traffic control protocols that potentially suffer from performance problems or high router resource consumption due to the estimation of the network parameters, the IntelRate controller can overcome those fundamental deficiencies. To verify the effectiveness and superiority of the IntelRate

controller, extensive experiments have been conducted in OPNET modeler. In addition to the feature of the FLC being able to intelligently tackle the nonlinearity of the traffic control systems, the success of the IntelRate controller is also attributed to the careful design of the fuzzy logic elements.

## References

- [1] M. Welzl, Network Congestion Control: Managing Internet Traffic. John Wiley & Sons Ltd., 2005.
- [2] R. Jain, "Congestion control and traffic management in ATM networks: recent advances and a survey," Computer Networks ISDN Syst., vol. 28, no. 13, pp. 1723–1738, Oct. 1996.
- [3] V. Jacobson, "Congestion avoidance and control," in Proc. 1988 SIGCOMM, pp. 314–329.
- [4] V. Jacobson, "Modified TCP congestion avoidance algorithm," Apr. 1990.
- [5] K. K. Ramakrishnan and S. Floyd, "Proposals to add explicit congestion notification (ECN) to IP," RFC 2481, Jan. 1999.
- [6] D. Katabi, M. Handley, and C. Rohrs, "Congestion control for high bandwidth-delay product networks," in Proc. 2002 SIGCOMM, pp. 89–102.
- [7] S. H. Low, F. Paganini, J. Wang, et al., "Dynamics of TCP/AQM and a scalable control," in Proc. 2002 IEEE INFOCOM, vol. 1, pp. 239–248.
- [8] S. Floyd, "High-speed TCP for large congestion windows," RFC 3649, Dec. 2003.
- [9] W. Feng and S. Vanichpun, "Enabling compatibility between TCP Reno and TCP Vegas," in Proc. 2003 Symp. Applications Internet, pp. 301–308.
- [10] M. M. Hassani and R. Berangi, "An analytical model for evaluating utilization of TCP Reno," in Proc. 2007 Int. Conf. Computer Syst. Technologies, p. 14-1-7.
- [11] N. Dukkupati, N. McKeown, and A. G. Fraser, "RCP-AC congestion control to make flows complete quickly in any environment," in Proc. 2006 IEEE INFOCOM, pp. 1–5.
- [12] Y. Zhang, D. Leonard, and D. Loguinov, "JetMax: scalable max-min congestion control for high-speed heterogeneous networks," in Proc. 2006 IEEE INFOCOM, pp. 1–13.
- [13] B. Wyrowski, L. Andrew, and M. Zukerman, "MaxNet: a congestion control architecture for scalable networks," IEEE Commun. Lett., vol. 7, no. 10, pp. 511–513, Oct. 2003.

[14] Y. Zhang and M. Ahmed, "A control theoretic analysis of XCP," in Proc. 2005 IEEE INFOCOM, vol. 4, pp. 2831–2835.

[15] Y. Zhang and T. R. Henderson, "An implementation and experimental study of the explicit control protocol (XCP)," in Proc. 2005 IEEE INFOCOM, vol. 2, pp. 1037–1048.

[16] J. Pu and M. Hamdi, "Enhancements on router-assisted congestion control for wireless networks," IEEE Trans. Wireless Commun., vol. 7, no. 6, pp. 2253–2260, June 2008.

[17] F. Abrantes, J. Araujo, and M. Ricardo, "Explicit congestion control algorithms for time varying capacity media," IEEE Trans. Mobile Comput., vol. 10, no. 1, pp. 81–93, Jan. 2011.

## Author Profile



**T. HARI** received the B Tech degree in information Technology from Yogananda institute of technology & Science in 2012 and M .tech. degree in Computer Science & Engineering from K M M Institute of Technology in 2014(pursuing), respectively.

**Second Author: Mr. P.Hemanth Kumar** M.Tech., working as an Assistant Professor in the Department of Computer Science and Engineering, K M M College of Engineering (affiliated to JNTU Anantapur), Tirupati, Andhra Pradesh, India.