

“The Advanced Prolong Montroller & Recording System” using Wireless, Distributed DAS Technology

Mr. Manesh V.Raut¹, Prof. Rupali S.Khule²

^{1,2}University of Pune, Matoshri College of Engineering and Research Centre,
Dept. of Electronics and Telecommunication Engg., Eklahare-Nashik, India.
raut.manesh@rediffmail.com

Abstract: Almost in most industries there is a mounting need for high-ceilinged quality, efficiency and machine-plant environment monitoring systems. Moreover, so many industrial operation monitoring is necessary to record, analyze or control in order to have implementations of proper, cost-effective and wastage free or maintenance free Production and also to reduce repair/replacing strategies. Therefore, here “The Advanced Prolong Montroller & Recording System” using Wireless, Distributed DAS Technology is proposed as good, important system engineering.

In this project, a wireless network for in-field operation, on time monitoring of multiple different area parameters like temperature, humidity is projected. The system network is arranged as able to sink operation-related data of remarkable areas to one central point, also called as master station. This master device is also automatically managing the communication with all remote monitoring stations distributed at different areas. Furthermore it will communicate with PC for data saving/recording & analyzing in the form of table & graphs.

Keywords: Prolonged; Distributed DAS; wireless Master and Slave sub units.

1. Introduction

In most modern pharmaceutical industries/plants/machine units there is a growing need for high quality, efficiency and availability in process, machine-plant environment prolonged monitoring systems. “The Advanced Prolong Montroller & Recording System” using Wireless, Distributed DAS Technology comprises three phases for data flow from parameter sensing to final destination at PC side. These are 1st phase-parameters sensing by different remote units, called as slave, 2nd Phase all slaves linked to single central unit called master and 3rd Phase from master to host PC as a final destination.

In this project, a number of hardware/software platforms, sensors and modules are chosen as per design requirement, cost effective and efficient to design, develop & implement “The Advanced Prolong Montroller & Recording System” using Wireless, Distributed DAS Technology.

1.1 The Challenges & Needs for System

The Remote data sensing units which constitute the wireless nodes which are made up with the sensor modules, processor modules, wireless communication modules and the energy supply modules. The required fetchers are the mutual coordination between each node, the computing power of each node, the limits of storage capacity and communications bandwidth, a variety of application types,

and work in poor working environment. In addition wireless sensor network nodes commonly used battery-powered, and reducing the power consumption to extend the lifetime has always been a major challenge. [8] The Energy (Storage) Challenges, These challenges needs to overcome in present and future too. [12]

1.2 Problem Statement

“The Advanced Prolong Montroller & Recording System” using Wireless, Distributed DAS Technology is designed, developed and experimentally tested. In this project theoretical and experimental investigations are carried out for enhancement of the wireless monitoring/recording techniques. Industrial, Scientific and Medical (ISM) radio band of frequencies (700MHz or 2.4GHz to 2.5 GHz and also 5.7 GHz to 5.8 GHz) may be used for the wireless communication operation.

The protocol, procedure and code of behavior are used to improve deployment and commissioning of the wireless set-up which are time and manpower overshadowing tasks. Therefore, it has may be regarded as one of the main cost factors when using and implementing one such net system.

Also node placement in industrial surroundings is not easy and random because each node has to perform an unambiguous task e.g., monitoring a specific machine/plant area. All operational data is provided by a remote device that is able to read working status as temperatures, humidity and performs several operations.

The master device is also required to automatically manage the communication with all remote stations & when plugged to PC for data Recording & Analyzing in the form of Table & Graphs. The resulting data acquisition of the system will be as shown in following figures. [1] Example graphs are shown in fig.

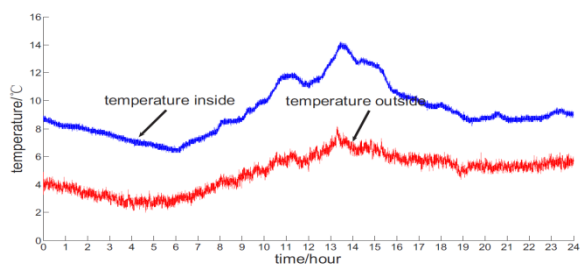

Figure 1: Graph Temperature Vs Time in Hour

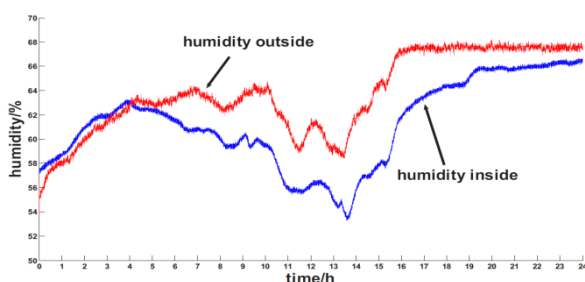

Figure 2: Graph Humidity % Vs Time in Hour

2. Impact & Significance of Proposed System

In modern edge, when it comes to the use of electronic equipment in pharmaceutical production, the de facto standards are set by the International Society of Pharmaceutical Engineers (ISPE) Good Automated Manufacturing Practice (GAMP) guidelines. Adopted by countries worldwide, these guidelines set down the main requirements that need to be considered when planning and implementing computerized systems in Pharmaceutical applications.

Traditionally it used the manual inspection methods which can't realize on-site and real-time monitoring and control. In most pharmaceutical industries/plants/machine units there is a highly need for high quality, efficiency and data availability in process, machine-plant environment monitoring systems. The replacement of traditional large wired monitoring devices is possible by means of new wireless technologies, which make the implementation of high level integration wireless devices. [12]

In modern edge of technology the rapid development of smart sensors, advanced processors/controllers, and wireless network, it is possible a reliable technological condition can be provided for our system automation. The automatic real-time monitoring of different parameters is also possible like temperature, humidity, pressure, fire, smoke etc. for Industry/machine working plants or even in environmental conditions like rainfall, fires in forest. [8]

Most of the (pharmaceutical) industrial process, machine operations, working conditions monitoring is very important & necessary to record, analyze or control. The advance and smart way to achieve these imp requirements for monitoring system is "The Advanced Prolong Montroller & Recording System" using Wireless, Distributed DAS Technology.

This project presents a new type of DAS systems engineering which use wireless remote nodes with precise sensor to collect the information from different sections in industry & forms a network. The wireless sensor nodes constitute a "smart" sensing, monitoring through the self-organization and transmits the data to the master center node through the wireless network. The master node moreover wired to PC for recording & analysis the data Purpose.

Thus we can achieve the remote distributed data acquisition system for monitoring & with recording, analyzing of the different parameters.

2.1 Proposed System Model as a Solution

The Schematic Implementation Model for "The Advanced Prolong Montroller & Recording System" using Wireless, Distributed DAS Technology is as follows.

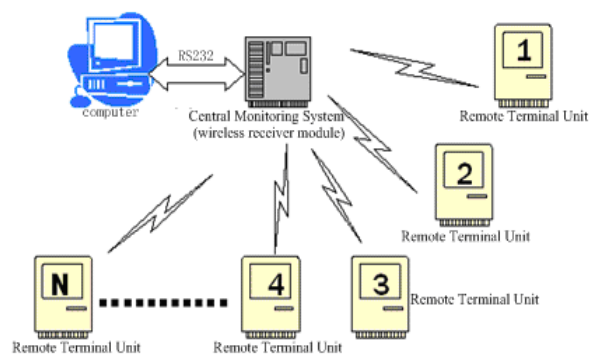

Figure 3: System Model Implementation [9]

3. System Hardware Overview

The proposed system as "The Advanced Prolong Montroller & Recording System" using Wireless, Distributed DAS Technology is basically consists of three different types of sub systems, all which are communicate each other smartly. These subsystems are as follows:

1. Remote Monitoring Nodes
2. Central Monitoring Node
3. PC System (Portable Computer system)

3.1 Remote Monitoring Smart Nodes (Slave Units)

Each Remote Terminal constitutes of different types of Hardware Integration as sub system shown in fig.4, fig.5 that are listed as follows:

1. PIC16F877 Mc with Embedded Firmware
2. On Chip ADC Converter & Buffers
3. EEPROM Memory AT24C1024
4. Different Sensor Modules (Temp Humidity)
5. Wireless Trans Receiver Module HAC UM 96/433MHz
6. Real Time Clock RTC PCF 8583
7. Indicators using LEDs
8. Power Supply & Battery.

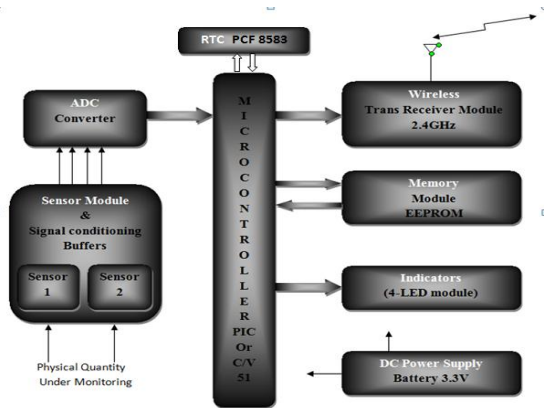

Figure 4: Schematic Block Diagram for Remote Monitoring Smart Node



Figure 7: Central Monitoring Master Node HW (ARM7 LPC 2478)

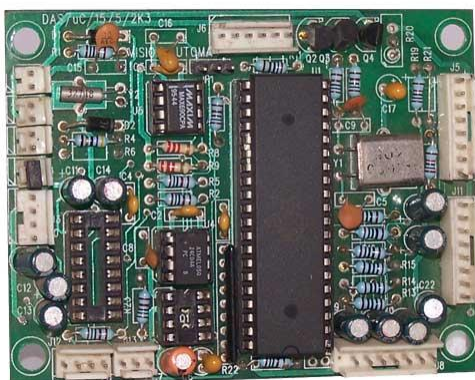

Figure 5: Smart Slave Node HW (PIC 16F877)

3.2 Central Monitoring Smart Node (Master Unit)

Central Monitoring System constitutes of different types of great Hardware Integration & that are listed as follows: 1) ARM7 Microcontroller With Embedded Firmware will be written in 'C' 2) Wireless Trans Receiver Module using free ISM band 3) Wired Serial Communication With PC Using USB 4) Memory Modules SDRAM & SD/MMC 5) LCD/TFT Screen/KEY Pad modules 6) Indicators module 7) Control Card with transistorized output 8) Power Supply & battery.

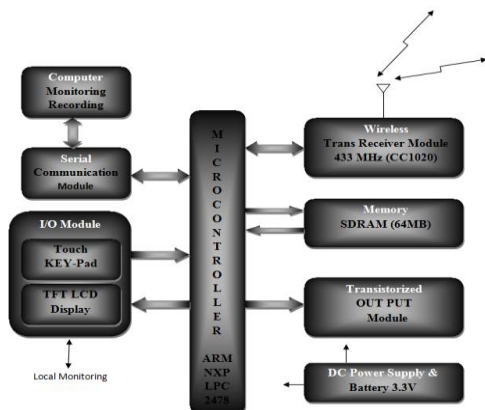

Figure 6: Block Diagram for Central Monitoring Smart Node

3.3 Significance of PC (Host System)

The PC System will equip with application software for “The Advanced Prolong Montrroller & Recording System” using Wireless, Distributed DAS Technology, which monitors & records sensed parameter with respect to time. Such application soft-wares are generally written in VB/C# computer high level language using .net Studio IDE.

The sensors, the hardware control structure and the design, function and module structure of the monitoring software of the system are important considerations. The com buses can improve the reliability and real-time of the system. The measurement and control system can better achieve the automatic control and real-time data acquisition. It also realizes the intelligent and scientific management in the modern greenhouse. The resulting data acquisition of the system will be as shown in following figures fig.8 & fig.9.



Figure 8: Weekly Graph View

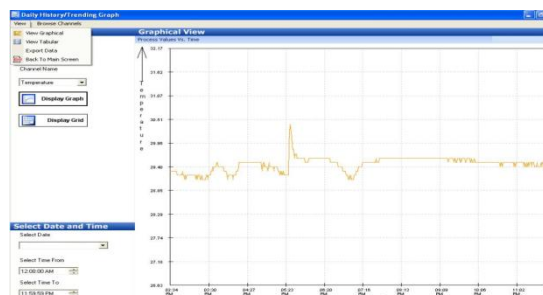
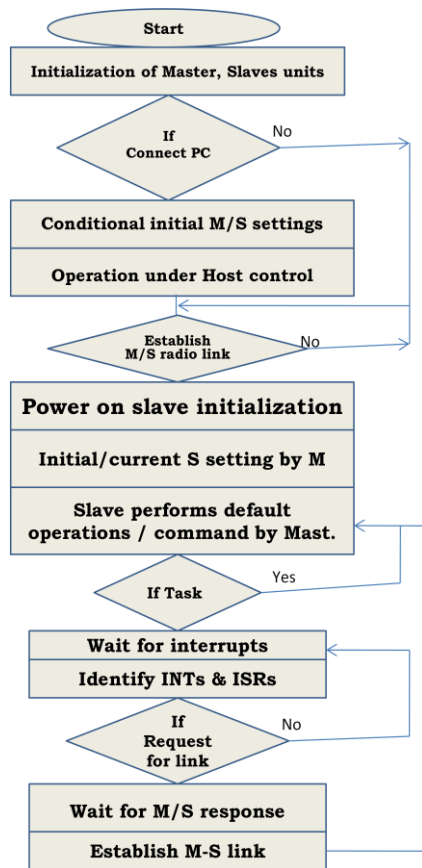

Figure 9: Daily Graph View

3.4 Operational Flow



3.5 System Application

The idea of proposed system offers its versatile application in different areas, Significant Advantages & Flexibility. Ex: Global regulatory requirements for the manufacturing, storeroom, stability chambers and distribution of thermally labile pharmaceutical yield have emphasized the consequence of assuring that product quality and integrity are not compromised.

4. Advanced Electronic Contrivances for Projected System

In this Advanced Technological era there is need to update ourselves about latest advancements in every field Data Acquisition design & development Engineering, Auto Management of variable parameters in the system through remote Monitoring & Recording etc. Therefore being as a system engineer/developer we have to update ourselves in HW/SW technologies along with highly developed modules are as follows.

4.1 Advanced Sensor Modules

As per industrial standards Most actuators use 0~10mA, 4~20mA and 0~5V as electrical interfaces sensor output standard signals. [6] The precise sensing device is used as a front end of Remote Node Units. These sensing devices are integrated with circuit for smart acquisition & control called as advanced sensor module. For example: Humidity and Temperature Sensor module HC2-ROPCB which offers the best possible reproducibility and a superb system accuracy of $< \pm 0.8 \%RH$ and $\pm 0.1 K$.



Figure 10: HC2-ROPCB modules for customer's specific

4.2 PIC Microcontroller In Slave Node

As per Design considerations & requirement Implementation of remote terminal is made using PIC 16F877 Microcontroller for measurement accuracy, low power consumption, high reliability and a simple structure. Peripherals like EEPROM, RTC, and RS232 also needed to implement a data acquisition system. [2] PIC16F877 it is Flash-Based, 8-Bit CMOS Microcontrollers With Nano Watt Technology Offers High-Performance RISC CPU & Low-Power Features: Standby Current: 50 nA @ 2.0V, typical, Operating Current: 11 μ A @ 32 kHz, 2.0V, typical 220 μ A @ 4 MHz, 2.0V, typical. PIC16F877 integrates 10-bit ADC converter, 8-channel module, which can make things easier hardware design and reduce costs. [3] These sub-systems are equipped with embedded firmware written in 'C' language. Furthermore the sub-system also having EEPROM to store collected data from advanced sensor modules. This sub-system is proposed for Humidity and Temperature Sensor module & Pressure Sensor.

4.3 ARM7 Microcontroller In Master Node (NXP LPC2478)

The Design & Implementation of ARM Based Data Acquisition System presented here is an intelligent remote unit based on embedded technology for data acquisition, monitoring and output control. This system is very much compact in design, as it uses a highly integrated 32-bit RISC microcontroller. This Device has high performance and offers the widest range of features viz., flexibility, reliability, durability, when compared with conventional and old solutions to control and data acquisition. [6]

4.4 Memory Modules

Acquired data at remote node is stored into a non-volatile memory using AT24C1024 EEPROM with I2C serial interface. This memory is organizes as a circular buffer to assure continuous data recording. For Master Node SDRAM Memory Modules are used. Amount of the data acquisition module is usually relatively large, so we need specialized memory chips for the module configuration. [2] [3].

4.5 Wireless Trans Receiver Module

The short-range wireless communication is advantageous as lower cost and flexibility. [8][9] It is required in the military, environmental monitoring, agriculture, medical and health etc. The Different Wireless Trans Receiver RF Modules Are Available like nRF9E5 /nRF24L01Single Chip 2.4GHz, Zig-Bee Transceiver module, and low cost HAC UM 96/433MHz.Zig-Bee Transceiver module having transmission range up to 1.6 km and baud rate of 115.200 bps data[7][8][10]. The proposed system only required to communicating in between 50 meters, so use of zig-bee will be regret. System uses wireless RS232 (HAC UM96 module).



Figure 11: wireless RS232 (HAC UM96 module)

4.6 Modbus

The Subsystems inter Communication is implemented by means of MODBUS protocol. Mod bus frame encompass of PDU & ADU to map protocol on N/W [4].

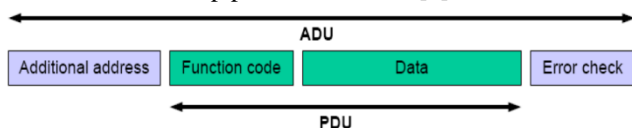

Figure 12: Mod bus frames

4.7 USB

It is used for data saving and analysis by mean of PC. USB interface offers Plug n Play, speed, feasible communication. In this project on chip USB HW is used to connect to a PC. [5]



Figure 13: Good Manufacturing Practices

5. Conclusion

The proposed system encompass sub systems, all which are communicate each other smartly and offers its versatile application in different areas, with significant advantages & flexibility. 1) As Slave Node for remote sensing and measuring is implemented by means of PIC16F877 reduces required peripheral HW and improving power efficiency 2) Master Node as implemented by means of ARM7LPC2478 provides smartness to Central Monitoring and 3) PC System with application software for setting, data Recording, and Analyzing. Continued existence of good manufacturing practices and requirements of premises, plant and equipment for pharmaceutical products, can't endurance without "The Advanced Prolong Monitoring & Recording System" Using Wireless, Distributed DAS Technology as good, important system engineering. World health worry in past, present & future could not be sustained without implementation of the Projected System in smart way in all respect.

References

- [1] JIANG YongXiang, QIN LinLin, SHI Chun, WU Gang "Design and Implementation of the Measurement and Control System Based on CAN Bus in Modern Greenhouse" Chinese control conference, July 25-26,2012.
- [2] C. Petrescu, C. Lupu, F.S. Tudor and M. Azzouzi, "Data Acquisition System for Recording of Photovoltaic Panel Power" 2013 2nd International Conference on Systems and Computer Science (ICSCS)Villeneuve d'Ascq, France, August 26-27, 2013 IEEE 2013.
- [3] Hongmin Wang , Zhu jie , Xufei Nie and Dandan Li "Design of PIC microcontroller-based high-capacity multi-channel data acquisition module" 2012 International Conference on Measurement, Information and Control (MIC) IEEE 2012.
- [4] Aryuanto Soetedjo, Yusuf Ismail Nakhoda, Dana Suryadi "Development of Data Acquisition System for Hybrid Power Plant" IEEE 2013.
- [5] Yanpeng Wang, Mingming Fu "A Portable USB Data Acquisition System" 2010 WASE International Conference2010.
- [6] Mahboob Imran Shaik "Design & Implementation of ARM Based Data Acquisition System" IEEE 2011.
- [7] M. S. de Castro, R. C. S. Freire, E. G. Costa, N. S. S. da Fonseca, M. A. O. Rodrigues "Wireless System for Detecting High Intensity Current Impulses Applied to Ground Grids"2013.
- [8] Chen Xueli, Ci Wenyan, Cai Suhua, Yao ying "Role of Wireless Sensor Networks in Forest Fire Prevention" IEEE 2010.
- [9] CAI Jun & LIU Jing-li "A Wireless Data Acquisition and Transmission System Design" IEEE 2009.
- [10] HUANG Xin-bo, SUN Qin-dong,Han Xiao-yan "An On-line Monitoring System of Temperature of Conductors and Fittings Based on GSM SMS and Zigbee" IEEE 2008.
- [11] Panfeng Zhang, Kaisheng Zhang "A Remote Sleep-monitoring Medical Alarm System" IEEE 2010.
- [12] Cai Ken,Liang Xiaoying "Development of Remote Monitoring Cardiac Patients System Based on GPRS" IEEE 2010.
- [13] Shen Jin, Song Jingling, Han Qiuyan, Wang Shengde, Yang Yan "A Remote Measurement and Control System for Greenhouse Based on GSM-SMS" IEEE 2007.
- [14] Elena I. Gaura, James Brusey, John Kemp, and C. Douglas Thake "Increasing Safety of Bomb Disposal Missions: A Body Sensor Network Approach" IEEE Transactions Vol. 39, NO. 6, Nov 2009.
- [15] Murali Krishna Telaprolu, V. Varun Sarma, Kondagunturi Varun, E. K. Ratnakanth, S. Narasimha Rao, Vinay Banda "Microcontroller Based Automation of Variable Electronic Speed Governor" IEEE 2009.
- [16] J. Pedro Amaro, Fernando J.T.E. Ferreira, Rui Cortesao, Nelson Vinagre and Rui P. Bras "Low Cost Wireless Sensor Network for In-Field Operation Monitoring of Induction Motors" IEEE 2010.

Other references

- [1] For(World Health Organization WHO Technical Report Series, No.961,2011)http://apps.who.int/prequal/info_general/documents/TRS961/TRS961_Annex5.pdf