

Performance Analysis of Shunt Active Power Filter Using Pi Controller

Md. Jahid Hasan¹, Ahmed Abdullah², Apu Samadder³

¹American International University-Bangladesh, Dept. of Electrical and Electronic Engineering,
House # 9B, Road #29, Pallabi, Mirpur – 12, Dhaka - 1216, Bangladesh.
junctionjahid@gmail.com

²American International University-Bangladesh, Dept. of Electrical and Electronic Engineering,
344 Polashbagh, West Rampura, Flat#A-2, Rampura, Dhaka-1219, Bangladesh.
ahmedabdullahrimon@live.com

³American International University-Bangladesh, Dept. of Electrical and Electronic Engineering,
Road # 08, House # 20, Nikunjo-2, Dhaka, Bangladesh.
apuee73@gmail.com

Abstract: This paper presents the improvement of power quality in three phase four wire system with balanced and unbalanced source condition based on three phase shunt active power filter. The PI controller is used to regulate the DC link voltage. The synchronous reference frame (SRF) method is used for extracting reference current. The PWM controller is used to generate gate pulses and applied to three phase VSI based shunt active power filter with split capacitor topology. The main aim of this paper is to reduce the total harmonic distortion (THD) in the source current. The MATLAB/Simulink environment is used to model for three phase source and nonlinear load is connected to the system.

Keywords: Shunt active power filter, SRF method, PWM, PI controller.

1. Introduction

The need for effective control and efficient use of electric power has resulted in massive proliferation of power semiconductor processors/converters almost [1] all areas of electric power such as in utility, industry and commercial applications. This has resulted in serious power quality problems, since most of these nonlinear converters contribute to harmonic injection into the power system, poor power factor, unbalance, reactive power burden [2] etc. The vulnerability of equipment in automated processing industry to poor power quality leads to heavy losses. Conventionally, passive L-C filters were used to eliminate line harmonics [5]. However, the passive filters have the demerits of fixed compensation, Bulkiness, and occurrence of resonance with other elements. The recent advances in power semiconductor devices have resulted in the development of active power filters (APF) for harmonic suppression [7]. Various topologies of active power filters have been proposed for harmonic mitigation.

The shunt APF based on voltage source inverter (VSI) structure is an attractive solution to harmonic current problems. The shunt APF is a pulse width modulated (PWM) voltage source inverter that is connected in parallel [3] with the load. It has the capability to inject harmonic current into the ac system with the same amplitude but in opposite phase of the load [4]. The principal function of shunt active filter is compensation of load harmonic current i.e. it confines [8] the load harmonic current at the load terminals, hindering its penetration into power system. The principal components of the APF are

VSI, a DC energy device that in this case is capacitor [9] and the associated control circuits. The performance of an active filter depends mainly on the technique used to compute the reference current and control method used to inject the desired

compensation current into the line [6]. The proposed work contains [10] the three phase source connected to the diode bridge rectifier. The active filter is connected in parallel to load. The SAPF contains VSI connected in series with an inductor which acts as filter because of its high switching frequency. So inverter itself produces high frequency current with low state loss. The structure of SAPF for three phase four wire system is shown in Fig.1. The inverter [13] circuit triggering depends on the control circuit output. The proposed system use PWM control to produce the pulse to trigger gate of IGBT. Instantaneous Synchronous reference frame (SRF) method is used in the proposed system to derive the compensating signal.

Figure 1: Structure of three phase four wire APF

2. Proposed Converter Strategies

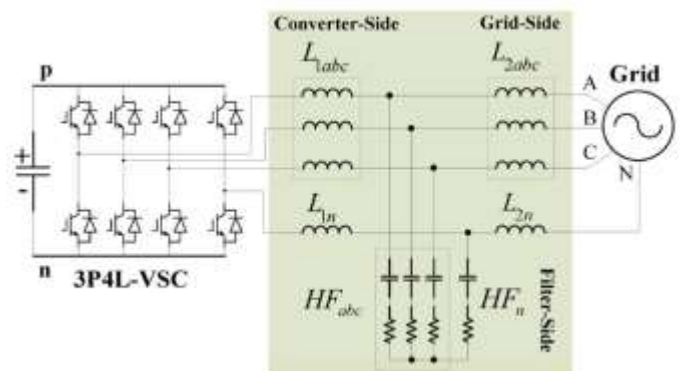

2.1 (a) Phase Locked Loop (PLL)

The basic function of the PLL [12] is a feedback system with a PI-regulator tracking the phase angle. Input is the three phases of the grid voltage and output from the PLL is the phase angle

of one of the three phases. In the power supply substation there will be one inverter leg for each of the three phases. There are two alternatives, [14] either assuming the grid voltages are in balance and track only one of the phases and then shift with 120 degrees for each of the other two phases or having three PLL system one for each phase. The main advantage of this method is best suitable for harmonic compensation with sinusoidal and non-sinusoidal source voltage [16]. The Fig.2. Shows the Block diagram of synchronous frame phase locked loop.

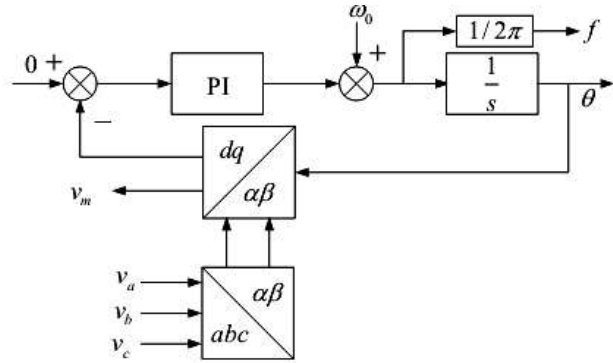

Figure 2: Block diagram of SF-PLL

2.1 (b) Synchronous Reference Theory

In this method only the currents transformed and the p-q formulation is [17] on the instantaneous active i_d and reactive components. If the d-axis direction as the voltage space vector, sequence component of the current. Therefore, the id- iq method can be expressed given below

$$\begin{bmatrix} i_d \\ i_q \\ i_o \end{bmatrix} = \frac{1}{v_{\alpha\beta}} \begin{pmatrix} v_\alpha & v_\beta & 0 \\ -v_\beta & v_\alpha & 0 \\ 0 & 0 & v_{\alpha\beta} \end{pmatrix} \begin{bmatrix} i_{Ld} \\ i_{Lq} \\ i_{Lo} \end{bmatrix} \quad (1)$$

In this strategy, the source must deliver the of the direct-axis component of the load compensation and power factor correction). Source Current can be calculated as follows:

$$\begin{cases} i_{sd} = \bar{i}_{Ld} \\ i_{sq} = i_{so} = 0 \end{cases} \quad (2)$$

$$i_{Ld} = \frac{v_\alpha i_{L\beta} + v_\beta i_{L\alpha}}{v_{\alpha\beta}} = \frac{P_{L\alpha\beta}}{\sqrt{v_\alpha^2 + v_\beta^2}} \quad (3)$$

The dc component of the above equation will:

$$\bar{i}_{Ld} = \left(\frac{P_{L\alpha\beta}}{v_{\alpha\beta}} \right)_{dc} = \left(\frac{P_{L\alpha\beta}}{\sqrt{v_\alpha^2 + v_\beta^2}} \right)_{dc} \quad (4)$$

Where the subscript “dc” means the average expression within the parentheses.

Since the reference source current must be in phase the voltage at the PCC it is calculated coordinates by multiplying the above equation vector in the direction of the PCC voltage space vector (Excluding the zero-sequence component).

$$i_{sref} = \bar{i}_{Ld} \frac{1}{v_{\alpha\beta}} \begin{bmatrix} v_\alpha \\ v_\beta \\ 0 \end{bmatrix} \quad (5)$$

$$\begin{bmatrix} i_{saref} \\ i_{sbref} \\ i_{soref} \end{bmatrix} = \left(\frac{P_{L\alpha\beta}}{v_{\alpha\beta}} \right)_{dc} \frac{1}{v_{\alpha\beta}} \begin{bmatrix} v_\alpha \\ v_\beta \\ 0 \end{bmatrix} \quad (6)$$

$$\begin{bmatrix} i_{saref} \\ i_{sbref} \\ i_{soref} \end{bmatrix} = \left(\frac{P_{L\alpha\beta}}{\sqrt{v_\alpha^2 + v_\beta^2}} \right)_{dc} \frac{1}{\sqrt{v_\alpha^2 + v_\beta^2}} \begin{bmatrix} v_\alpha \\ v_\beta \\ 0 \end{bmatrix} \quad (7)$$

2.3. PI Controller

The control scheme consists of a PI controller, a limiter, and a three phase sine wave generator for reference current and switching signal generation. The peak value of the reference currents is estimated by regulating the DC link voltage. The actual capacitor voltage is compared with a set reference value. Figure 3 shows Reference current generation using SRF method with PI controller.

The error signal is then processed through a PI controller, which contributes to the zero steady error in tracking the reference current signal. The output of the PI controller is considered as the peak value of the supply current (I_{max}), which is composed of two components: (a) the fundamental active power component of the load current, and (b) the loss component of the APF; to maintain the average capacitor voltage at a constant value. The peak value of the current (I_{max}) so obtained, is multiplied by the unit sine vectors in phase with the respective source voltages to obtain the reference compensating currents. These estimated reference currents (I_{sa}^* , I_{sb}^* , and I_{sc}^*) and the sensed actual currents (I_{sa} , I_{sb} , and I_{sc}) are compared to a pwm, which gives the error signal for the modulation technique. This error signal decides the operation of the converter switches.

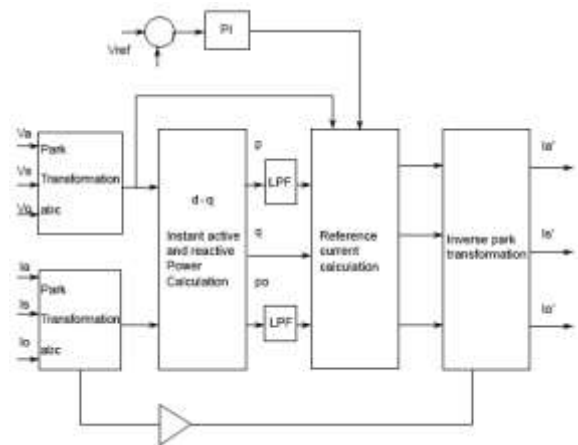

Figure 3: Reference current generation using SRF method with PI controller.

2.4. PWM controller

To control the shunt active filter a PWM logic controller is developed. The difference between the injected current and the reference current determine the modulation wave of the reference voltage. This voltage is compared with two carrying triangular identical waves shifted one from other by a half period of chopping and generate switching pulses.

3. Simulation Results

The simulation is carried out with three phase four wire system with non-linear load. Here the diode rectifier is used as non-linear load. The Fig-4 shows the circuit diagram without any filter or controller circuit. From this simulation, source current, voltages are taken as output. The resultant waveforms are shown in Fig-5 and Fig-6. THD value of source current under balanced and unbalanced source condition. The THD value is high because we won't use any controller in this circuit. The Fig.7 and Fig.8 shows the harmonic spectrum of open loop source current under balanced and unbalanced condition.

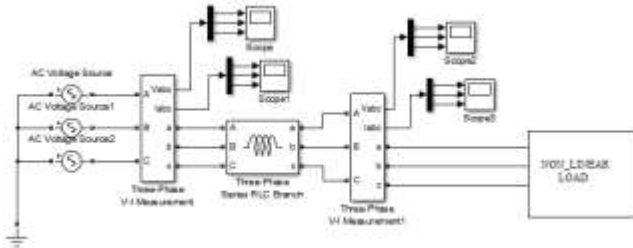

Figure 4: Simulation for open loop system.

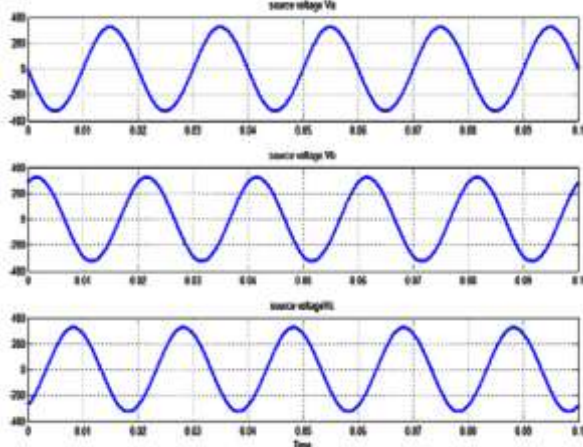

Figure 5: Simulation Waveform for open loop source voltage.

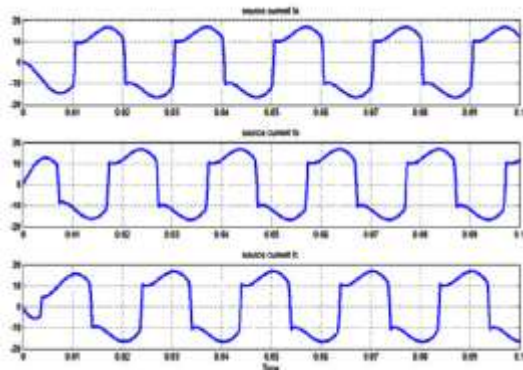

Figure 6: Simulation Waveform for open loop source current.

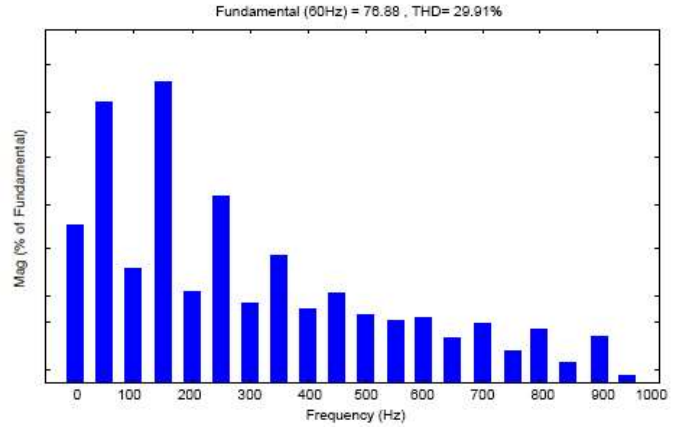

Figure 7: Harmonic Spectrum and THD value of open loop source current under balanced condition.

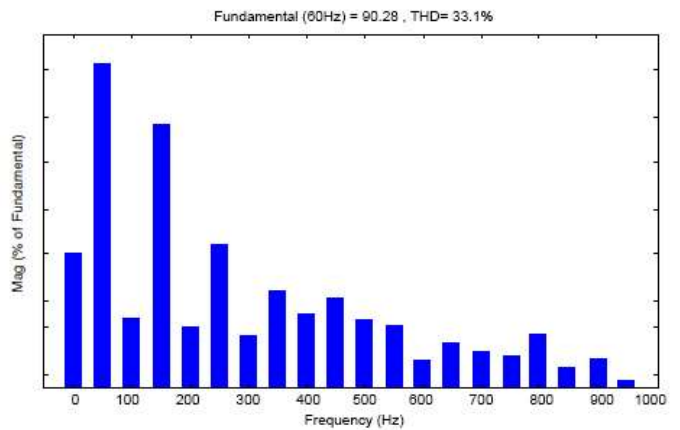

Figure 8: Harmonic Spectrum and THD value of open loop source current under unbalanced condition.

The Fig-9 shows the closed loop system with PI controller along with the SRF (Synchronous Reference Frame) theory. Using this SRF theory three phase system is converted into two phases, and the reference current is generated from this. This reference current is given as reference value and the actual current is taken from filter; these two are compared in PI controller and the error signal is generated.

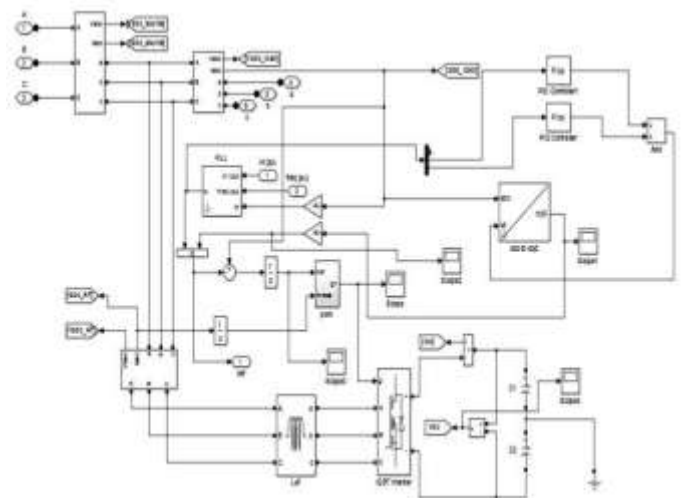

Figure 9: Simulation for SRF method with PI controller

This is again given as reference to the PWM controller to generate the PWM signal to the filter switch. Hence by turning on and off the devices the current waveform has been improved. The system parameters are shown in Table-1.

Table 1: System Parameter

System Parameter	Values
Source Voltage (Vs)	110V
Source frequency	50Hz
Source inductance(Ls)	0.01MH
Load impedance	15Ω, 60mH
DC link capacitance	3000Uf

The simulation results of source current, source voltage and load current are shown in Fig-10 to Fig-11 respectively. Similar to open loop, the T D value of source current is shown under balanced and unbalanced conditions in Fig-12 and Fig-13. Compared to the open loop system, closed loop THD value is less.

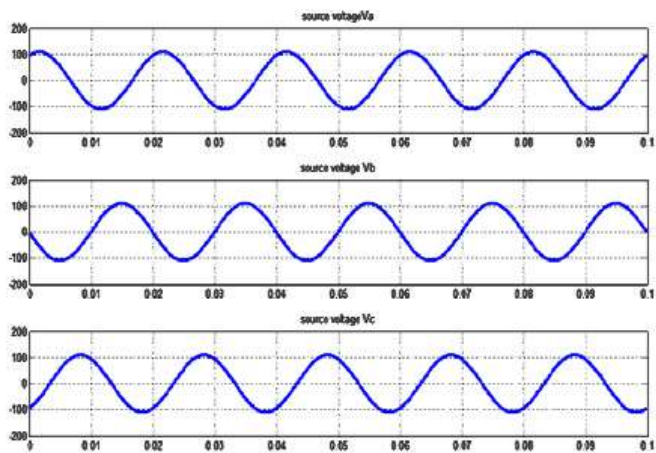

Figure 10: Simulation Waveform for source voltage using PI controller.

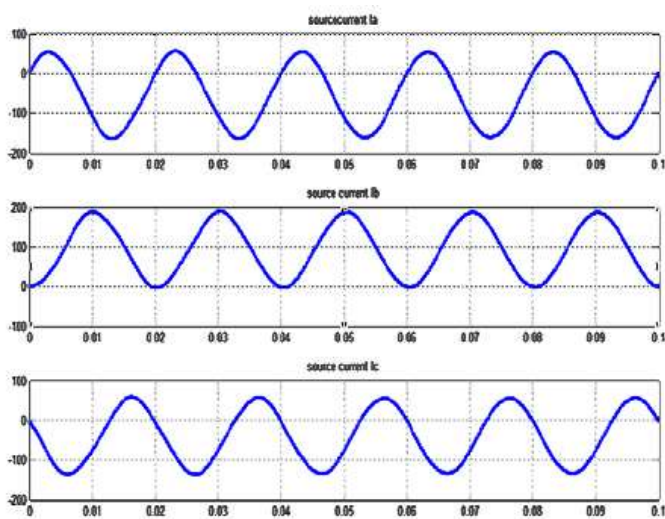

Figure 11: Simulation Waveform for source current using PI controller.

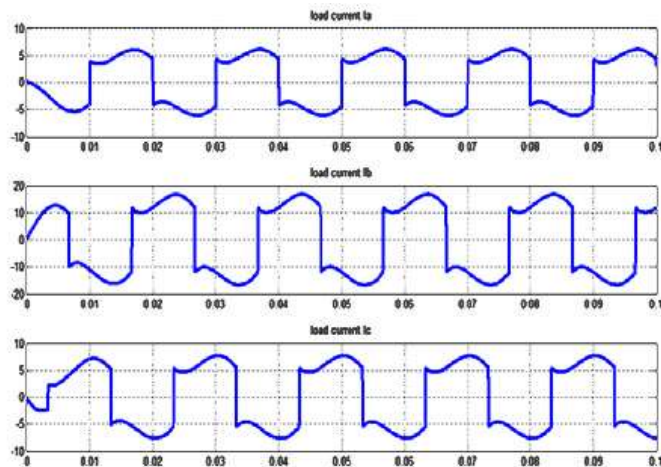

Figure 12: Simulation Waveform for load current using PI controller.

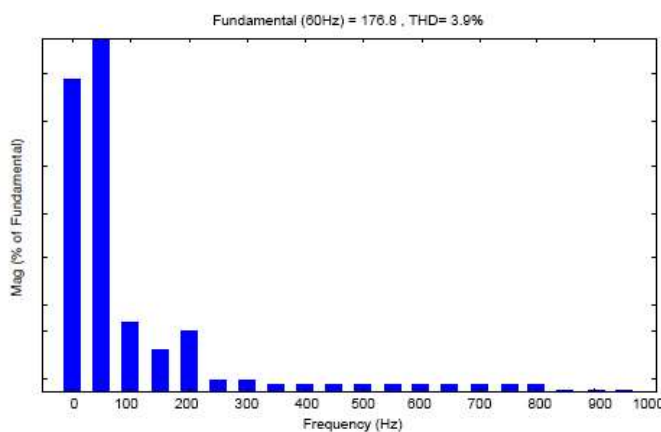

Figure 13: Harmonic Spectrum using PI controller with balanced condition.

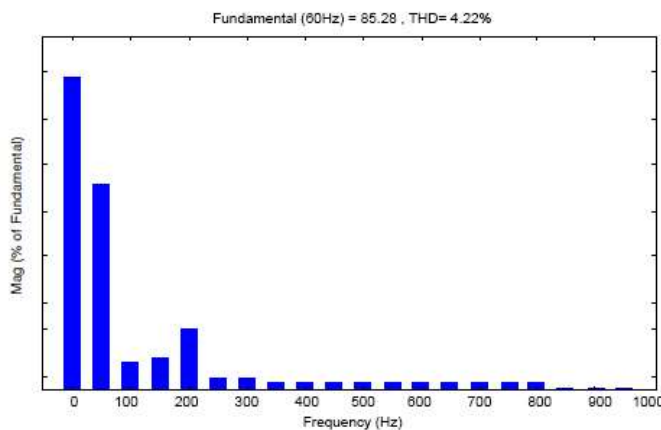

Figure 14: Harmonic spectrum using PI controller with unbalanced condition

The Table.2 shows the compared result of source current THD value under balanced and un-balanced condition with and without filter circuit.

Table 2: Comparison of Source Current THD value with and without Filter Circuit

Loop of operation	Source current balanced condition	Source unbalanced condition
Before filter	29.91%	33.1%
After filter	3.9%	4.22%

4. Conclusion

In this paper PI controller is developed and verified for three phase four wire systems. This method is presented by using closed loop with PI controller and also for generating gate pulse, PWM controller is used. The PI controller is capable of compensating current harmonics in three phase four-wire systems. By using the proposed method source current harmonics is reduced and THD value is tabulated. The simulation result is shown for both open loop and closed loop systems.

References

[1] H. Akagi "New trends in active filters for power conditioning,"IEEE Trans. Ind. Appl, Vol. 32, No. 6, pp. 1312-1322, Nov./Dec.1996.

[2] F. Z. Peng, G. W. Ott Jr., D. J. Adams, "Harmonic and reactive power compensation based on the generalized instantaneous reactive power theory for three-phase four-wire systems" IEEE Trans. Power Electron, Vol. 13, No. 5, Nov. 1998.

[3] V. Soares, P. Verdelho, and G. Marques, "Active power filter control circuit based on the instantaneous active and reactive current i_d-i_q method,"IEEE Power Electronics Specialists Conference, Vol. 2, pp

[4] M Suresh, A. K. Panda, S. S. Patnaik, and S. Yellasiri, "Comparison of two compensation control strategies for shunt active power filter in three-phase four-wire system," in Proc. IEEE PES Innovative Smart Grid Technologies, pp. 1-6, 2011.

[5] Fang Zheng Peng and Akagi, (1990), "A New Approach to harmonic Compensation in Power Systems A combined System of Shunt Passive and Series Active Filters", IEEE Transactions on Industrial Applications, Vol. 26, pp-6-11.

[6] Karuppanan P and Kamala kanta Mahapatra (2011), "PI with Fuzzy Logic Controller based Active Power Line Conditioners"- Asian Power Electronics, Vol. 5, pp-464468.

[7] Suresh Mikkili and Panda A.K. (2011), "PI and fuzzy logic controller based 3-phase 4-wire shunt active filter for mitigation of current harmonics with Id-Iq control strategy", Power Electronics (JPE), Vol.11, pp-914-21.

[8] Suresh Mikkili, Panda A.K. (2012), "Real-time Implementation of PI and Fuzzy logic controllers based shunt active filter control strategies for power quality improvement", ELSEVEIR: Electrical Power and Energy System, Vol.43, pp-1114-1126.

[9] Saad S and Zellouma L. (2009), "Fuzzy logic controller for three-level shunt active filter compensating harmonics

and reactive power", Electronics Power System Research, Vol.79, pp-1337-1341.

[10] S. K. Jain, P. Agrawal, and H. O. Gupta, "Fuzzy logic controlled shunt active power Filter for power quality improvement," Proceedings of Institute of Electrical Engineers, Electrical Power Applications, vol. 149, no. 5, 2002.

[11] Rodriguez P, Candela J.I, Luna A and Asiminoaei L. (2009), "Current harmonics cancellation in three-phase four-wire systems by using a four-branch star filtering Topology", IEEE Transactions on Power Electronics, Vol. 24, pp-1939-50.

[12] Kirawanich P and O, Connell R.M. (2004), "Fuzzy Logic Control of an Active Power Line Condoner", (2004), IEEE Transactions on Power Electronics, Vol. 19, pp-1574-1585.

[13] Zaniat Salam, Tan Perng Cheng and Awang Juosh. (2006), "Harmonics Mitigation using Active power Filter: A Technological Review"- Elekrika Vol. 8, pp-17-26.

[14] P. Kirawanich and R. M. O'Connell, "Fuzzy logic control of an active power line conditioner,"IEEE Trans. Power Electron. Vol. 19, No.6, pp. 1574-1585, Nov. 2004.

[15] M. I. M Montero, E. R. Cadaval, and F. B. Gonzalez, "Comparison of control strategies for shunt active power filters in three-phase four-wire systems," IEEE Trans. Power Electron., Vol. 22, No. 1, Jan. 2007.

[16] M. Aredes, J. Hafner, and K. Heumann, "Three-phase four-wire shunt active filter control strategies," IEEE Trans. Power Electron. Vol. 12, No.2, pp. 311-318, Mar. 1997.

Author Profile



Md. Jahid Hasan is under graduated from American International University Bangladesh (AIUB) in department of Electrical and Electronic Engineering. He is currently a Research Assistant with the Department of Electrical Engineering. His main research interests include power electronic converters, Renewable Energy and Technology and Organic Circuitry.



Ahmed Abdullah earned BSc from American International University-Bangladesh under the department Electrical and Electronics Engineering. He primarily develop projects on embedded system, but also has experience with Renewable Energy, Power System Protection.



Apu Samadder has completed B.Sc. from American International University-Bangladesh under the department of Electrical and Electronics Engineering. His core research area is power and energy systems emphasize all aspects of electrical energy, innovation in energy generation and distribution, grid intelligence, renewable resources and efficient devices.