

Iot Based Production Monitoring In Industry Using Wireless Sensor Networks

P .Sumithra¹, Dr.R.Nagarajan.M.E., Ph.D²

¹PG Scholar ,M.E Embedded System Technologies, Department of Electrical and Electronics Engineering, Gnanamani College Of Technology Namakkal, Tamilnadu, Anna University ,Chennai ,Tamilnadu, India.

²Professor, Department of Electrical and Electronics Engineering, Gnanamani College of Technology Namakkal, Tamilnadu, Anna University, Chennai, Tamilnadu, India

Abstract:

The objective of the project is to monitoring the production lines in industry using wireless sensor networks. This project presents the benefits of an automated data collection and display system for production lines. It involves wireless sensor networks for monitoring the productions in industry. Condition monitoring reduces human inspection requirements through automated monitoring, reduces maintenance through detecting faults before they escalate and improves safety and reliability. This work can monitor productions using temperature, voltage and current sensors with support of microcontroller. Relay is acts like a switch to monitor the production lines. In this project Global System for Mobile communication technique is used to transferring the collected data. The collection of data, it is transferred into computerize spreadsheet in the remote office by authorized personnel for reporting purpose. The system will generate an automated report which stays in place and the management only needs to act base on the results. This project is cost effective automatic data collection is the alternative to manual data collection. It significantly improves the accuracy of the valuable reports for the management. It also reduces the time for identifying the fault using this technique.

Keywords: Global System, Microcontroller, wireless sensor networks

1. Introduction:

1.1 Productions Monitoring:

In This Modern World Multinational Business Companies Were Increasing Rapidly. The Single Businessman Wants To Monitor All The Production Status In Each Industry With Manual Presence. So We Introduce A Project Industrial Monitoring System With GSM Telemetry .In Our Project That Business Man Can Monitors All The Production Status Through PC Or Mobile In The Corporate Office Itself. Mobile Phones Have Become A Widespread Means Of Communication. It Becomes A Part Of Everyday Life With Ever More People Enjoying The Service And Extra Freedom They Provide. It Works On The Basis Of Global System

For Mobile Communication. A Subscriber From Any Systems Can Access Telecommunication Services By Using A Subscriber Identify Module Card In A Handset Suitable For The Network On The Visited System. The Short Message Service Allows Text Messages To Be Sent And Received To And From Mobile Telephones. The Text Can Comprise Words Or Numbers Or An Alphanumeric Combination. Because Simple Person To Person Messaging Is Such An Important Component Of Total SMS Traffic Volumes, Anything That Simplifies Message Generation As Well As Extended Utility Of The SMS Being Sent Is An Important Enabler Of Short Message Service. Such Extended Utility Of SMS Fulfills Certain Important Requirements. This System Is Developed To Control The Functions Of

A Device From A Remote Area Through The SMS Of A Mobile Phone Using Micro Controller.

2. Literature Review:

2.1 Industry Monitoring:

Monitoring Systems Equipped With Sensors And Wireless Communication Can Reduce The Costs To A Small Percentage Of Conventional Monitoring Systems, And Will Increase Its Field Of Application. Due To The Detailed Information Of The Structural Behavior Of Bridges Obtained From The Monitoring System, Maintenance Costs Could Also Be Reduced, Since Inspection Methods Can Be Applied More Efficiently. Only After Certain Changes In The Structural Behavior Have Been Identified, Will Inspection Be Necessary, And Proper Repair Could Be Done Immediately After The Occurrence Of The Defect. This Reduces The Risk Of Further Damage. The Analysis Of Measured Data And The Knowledge Of Continuous Changes Of Structural Behavior Will Improve The Life Time Prognosis Of Civil Structures, And Reduce The Overall Maintenance Costs Of Buildings And Transport Networks. Data Has To Be Continuously Transmitted To The Supervisor. Each Sensor Device Which Is Itself A Complete, Small Measurement And Communication System, Has To Be Powered And Cost Optimized. Using Multi-Hop Techniques, The Data Of The Sensor Network Can Be Transmitted Over Short Distances Of Some 10 M From Each Hop To A Base Station On Site. At The Base Station The Data Items Are Collected And Stored In A Database For Subsequent Analysis. This Data Can Then Be Accessed By A Remote User. If The Central Unit Detects A Hazardous Condition By Analyzing The Data, It Raises An Alarm Message.

The Central Unit Also Allows For Wireless Administration, Calibration And Reprogramming Of The Sensor Nodes In Order To Keep The Whole System Flexible. Each Mote Is Composed Of One Or More Sensors, A Data Acquisition And Processing Unit, A Wireless Transceiver And A Battery Power Supply. The Acquisition And Processing Unit Usually Is Equipped With A Low Power Microcontroller Offering An Integrated Analogue To Digital Converter And Sufficient Data Memory To Store The Measurements. This Unit Also

Incorporates Signal Conditioning Circuitry Interfacing The Sensors To The ADC.

The Advancement In Wireless Communications And Electronics Has Enabled The Development Of Low-Cost Sensor Networks. The Sensor Networks Can Be Used for Various Application Areas .For Different Application Areas, There Are Different Technical Issues That Researchers Are Currently Resolving. The Current State Of The Art Of Sensor Networks Is Captured In This Article, Where Solutions Are Discussed Under Their Related Protocol Stack Layer Sections. This Article Also Points Out the Open Research Issues and Intends To Spark New Interests and Developments in This Field.

3. Block Diagram:

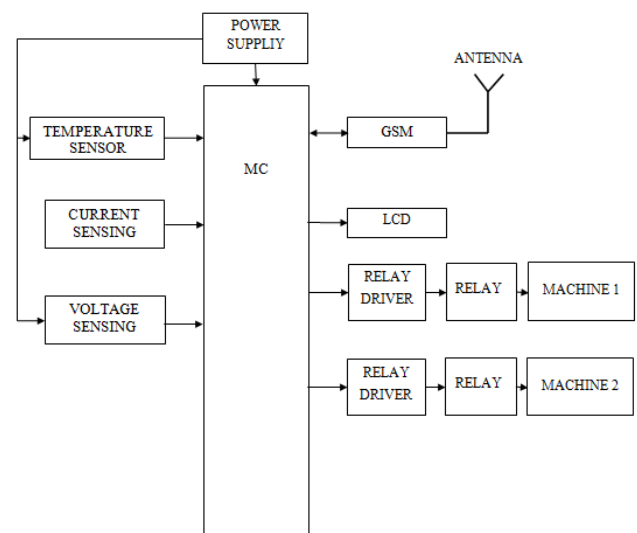

Figure 3.1: Block Diagram of Monitoring Section:

The Block Diagram Of The Production Monitoring Using Wireless Sensor Networks Is Shown In Figure 3.1. Here, The Block Diagram Shows The Overall Function Of This Production Monitoring System. The Temperature Sensor Is A Device Which Is Specially To Measure The Hotness Or Coldness Of An Object. It Can Measure More Accurately Than With A Thermister. Here, Temperature Sensor Used To Measure The High Or Low Voltage And High Or Low Current Of The Production Lines. Current Sensor And Voltage Sensor Is Which Carries The Require Current And Voltage To The Production Lines. Power Supply Given By The Network Of The Industry. Then The Whole Network Connected

Through The Microcontroller. Relay Is An Electrical Switch That Opens And Closes Under Control Of Another Electrical Circuit. When A Current Flows Through The Coil, The Resulting Magnetic Field Attracts An Armature That Is Mechanically Linked To A Moving Contact. Output Of The Production Monitoring Displayed By Using The Liquid Crystal Display. Before That The Output Is Collected Through The Global System For Mobile Communication To The Authority Of The Industry. Another Output Is Called Buzzer When Production Lines May Damaged It Will Be Sounds At The Industry.

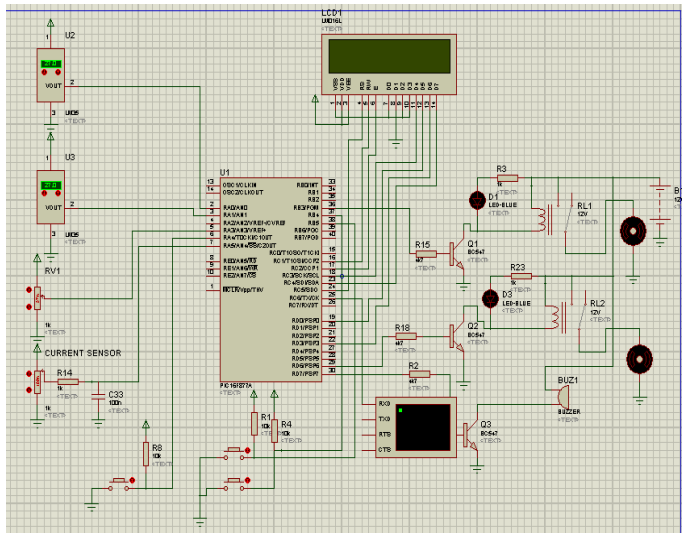

Figure 3.2 Circuit Diagram of Production Monitoring System

I. INDUSTRY MONITORING AND DATA COLLECTION OF THE PRODUCTION MONITORING SYSTEM SHOWN IN THE FIGURE 3.2. THE PIC16F877A HAS 40 PINS. THESE 40 PINS CAN BE CONNECTED TO DIFFERENT PORTS LIKE PORTA, PORTB, PORTC, PORTD AND PORTE. APART FROM THESE IT CAN BE USED FOR TRANSMITTING AND RECEIVING DIFFERENT ANALOG SIGNALS. OSCILLATORS, CAPACITORS, RESISTORS OF VARYING VALUE CAN BE USED WITH THIS. THE PORTS IN THIS CAN BE CONFIGURED AS EITHER AN OUTPUT PORT OR AS AN INPUT PORT .IF IT IS CONFIGURED AS OUTPUT PORT EITHER LED’S OR LCD’S OR SEVEN SEGMENT DISPLAYS CAN BE USED TO VIEW THE OUTPUT. IF THE PORTS ARE CONFIGURED AS INPUT THEN SIGNALS CAN BE RECEIVED BY USING KEYS. THESE PORTS HAVE 3-8 PINS. PORT A, B, C, D HAS EIGHT PINS EACH AND

PORT E HAS ONLY 3 PINS. SUPPLY OF +5V ARE USED IN PINS 1 AND 32 WHERE A RESISTOR OF 1K IS USED IN PIN 1.SIMILARLY PIN 31 IS USED AS GROUND. THIS IC IS PARTICULARLY USED FOR STORING VALUES IN ITS MEMORY. RTC (REAL TIME CLOCK) IS AN ADDED FEATURE. WHEN THERE IS A NEED TO USE FIVE PORTS OR LESSER THAN FIVE PORTS WE CAN ALWAYS GO FOR 877 SINCE IT GIVES US AN ADVANTAGE TO USE EEPROM, RTC AND DIFFERENT TYPES OF INPUT AND OUTPUT. THE CIRCUIT IS DESIGNED TO CONTROL THE BUZZER. THE BUZZER ON AND OFF IS CONTROLLED BY THE PAIR OF SWITCHING TRANSISTORS (BC 547). THE BUZZER IS CONNECTED IN THE Q2 TRANSISTOR COLLECTOR TERMINAL. WHEN HIGH PULSE SIGNAL IS GIVEN TO BASE OF THE Q1 TRANSISTORS, THE TRANSISTOR IS CONDUCTING AND CLOSE THE COLLECTOR AND EMITTER TERMINAL SO ZERO SIGNALS IS GIVEN TO BASE OF THE Q2 TRANSISTOR. HENCE Q2 TRANSISTOR AND BUZZER IS TURNED OFF STATE. WHEN LOW PULSE IS GIVEN TO BASE OF TRANSISTOR Q1 TRANSISTOR, THE TRANSISTOR IS TURNED OFF. NOW 12v IS GIVEN TO BASE OF Q2 TRANSISTOR SO THE TRANSISTOR IS CONDUCTING AND BUZZER IS ENERGIZED AND PRODUCES THE SOUND SIGNAL. IT HAS VCC, GND AND OUTPUT. THIS SENSOR PROVIDES VARIABLE VOLTAGE AT THE OUTPUT BASED ON TEMPERATURE. “LM35” PROVIDES OUTPUT IN DEGREE CELSIUS AND CAN SENSE UP TO 150 DEGREE CELSIUS TEMPERATURE. FOR EVERY +1 CENTIGRADE RISE IN TEMPERATURE THERE WILL BE +10MV HIGHER VOLTAGE AT THE OUTPUT PIN. THE AMOUNT PRODUCED BY IC2 AMPLIFIES IN AN AMOUNT TO THE TEMPERATURE BY 10 Mv PER DEGREE. THIS UNSTABLE VOLTAGE IS SUPPLY TO A COMPARATOR IC 741. OP AMPLIFIER IS THE MOST GENERALLY USED ELECTRONIC DEVICES TODAY. THE IC 741 OP-AMP IS ONE SORT OF DIFFERENTIAL AMPLIFIER. WE HAVE USED IC741 AS A NON-INVERTING AMPLIFIER WHICH MEANS PIN-3 IS THE INPUT AND THE OUTPUT IS NOT INVERTED. THIS LM35 TEMPERATURE SENSOR CIRCUIT AMPLIFIES THE DIFFERENCE BETWEEN ITS INPUT TERMINALS. THE ADVANTAGES OF TEMPERATURE SENSOR INCLUDE IT HAS NO EFFECT ON THE MEDIUM, MORE ACCURATE, IT HAS AN EASILY CONDITIONED OUTPUT AND IT RESPONDS INSTANTLY. THE TEMPERATURE SENSORS HAVE WELL KNOWN APPLICATIONS IN ENVIRONMENTAL

AND PROCESS CONTROL AND ALSO IN TEST, MEASUREMENT AND COMMUNICATIONS. A DIGITAL TEMPERATURE IS A SENSOR, WHICH PROVIDES 9-BIT TEMPERATURE READINGS. DIGITAL TEMPERATURE SENSORS OFFER EXCELLENT PRECISE ACCURACY, THESE ARE DESIGNED TO READ FROM 0°C TO 70°C AND IT IS POSSIBLE TO ACHIEVE $\pm 0.5^\circ\text{C}$ ACCURACY. THESE SENSORS COMPLETELY ALIGNED WITH DIGITAL TEMPERATURE READINGS IN DEGREE CELSIUS.

Relays Are Mainly Made For Two Basic Operations. One Is Low Voltage Application And The Other Is High Voltage. For Low Voltage Applications, More Preference Will Be Given To Reduce The Noise Of The Whole Circuit. For High Voltage Applications, They Are Mainly Designed To Reduce A Phenomenon Called Arcing. Light-Emitting Diodes Are Used In Applications As Diverse As Aviation Lighting, , Advertising, Camera Flashes, Lighted Wallpaper And Medical Devices. They Are Also Significantly More Energy Efficient And, Arguably, Have Fewer Environmental Concerns Linked To Their Disposal. The Color Of Light Emitted From An LED Is Neither Coherent Nor Monochromatic, But The Spectrum Is Narrow With Respect To Human Vision, And For Most Purposes The Light From A Simple Diode Element Can Be Regarded As Functionally Monochromatic.

4. Conclusion:

The Production Monitoring System Developed Is An Essential Production Tool In Industries For Both The Management And The Production Team. The Production Monitoring System Captures And Distributes Unadulterated Production Information At All Levels Along The Production Process Without Human Intervention. Data Collected Is Crucial And This Could Be Collected By Using A Real Time Production Monitoring System. With The Collected Data, Realistic Production Goals Can Be Achieved When Proper Analysis Is Done And Implementation Is Practiced. Events Occurring Can Also Be Displayed With The Help Of A Production Monitoring System. Production Faults Can Be Rectified Instantly. A Production Monitoring System Enables The Production Team To Operate Efficiently Optimizing All Available Resources Towards A Better Production In The Above Sequence That It Is Clearly Production Monitoring

System Along The Production Of The Human Intervention Data Information Of Real Time Production Hardware Modules Collected Data.

5. References:

- [1] E. Aboelela, W. Edberg, C. Papakonstantinou, And V. Vokkarane Of "Wireless Sensor Network Based Model For Secure Railway Operations," In Proc. 25th IEEE Int. Perform., Comput. Commun. Conf., Phoenix, USA, Pp. 1–6. 2006
- [2] M. Aguado Et Al., W. Edberg "Wimax On Rails: A Broadband For Communication Architecture For CBTC Systems," IEEE Veh. Technol. Mag., Vol. 3, No. 3, Pp. 47–Sep. 2008.
- [3] B. Aietal, Challenges Toward Wireless Communication For Highspeed Railway IEEE Trans Intell. Transp. Syst., Vol. 15, No. 5, Pp. 2143–2158., Oct. 2014.
- [4] K. Akkaya And M. Younis, "A Survey On Routing For Wireless Sensor Networks," In Ad Hoc Netw., Vol. 3, No. 3, Pp. 325–349, Dec., 2005.
- [5] I. Akyildiz, W. Su, Y. Sankarasubramaniam, And E. Cayirci, "Wireless Of Networks: A Survey,," Comput. Netw., Vol. 38, No. 4, Pp. 393–422, Mar. 2002.
- [6] I. Akyildiz, W. Su, Y. Sankarasubramaniam, And E. Cayirci, "A Wired Survey On Sensor Networks," IEEE Commun. Mag., Vol. 40, No. 8, Pp 102–114, Aug. 2002.
- [7] A. Anastasopoulos, K. Bollas, D. Papasalouros, and D. Kourousis Kourousis, "Acoustic Emission Online Inspection Of Rail Wheels," In Proc. 29th Eur. Conf. Acoust. Emission Testing, Wien, Austria, Pp. 1–8, 2010.
- [8] V. Balas And L. Jain, "World Knowledges For Sensors And Estimators By Models And Internals Model," J. Intell. Fuzzy Dissertation Syst., Vol. 21, No. 1, Pp. 79–88, Apr. 2010.
- [9] E. Berlin and K. Van Laerhoven, "Sensor Networks For Railway Monitoring Fuzzy: Detecting Trains from Their Distributed Vibration Footprints," By Model in IEEE Int. Conf. Distrib. Comput. Sens. Syst., Cambridge, MA, USA, Pp 80–87, 2013.
- [10] G. Ramachandran, "Implementation FPGA Of Motor Speed Control Using VHDL" Language (Xilinx) "International Journal Of Innovative

[11] M. Filigrano Et Al., “Real-Time Monitoring Of Railway Traffic Using fiber Optic Bragg Grating Sensors,” IEEE Sens. J., Vol. 12, No. 1, Pp. 85–92, Jan. 2012.