

Performance Analysis Of Various Phases Of Srm With Classical & New Compact Converter

S.M.Mohamed Saleem, L.Senthil Murugan

PG Scholar

Department of Electrical Drives and Embedded Control
RVS College of Engineering & Technology
Coimbatore, Tamil Nadu.

alvaajid@gmail.com

Assistant Professor,

Department of Electrical Drives and Embedded Control
RVS College of Engineering & Technology
Coimbatore, Tamil Nadu.

senthil2010@gmail.com

Abstract – In recent years, considerable attention has been given to find the compact and low cost power converter topology for Switched Reluctance Motor (SRM) drive to meet the emerging applications such as plotters, fans, pumps, screw rotary compressor drives, high speed application drives above 30,000 RPM. This paper is concerned with such as attempt to formulate a new compact power converter for SRM drive. The proposed power converter has reduced number of power electronic components which makes the converter compact and also reduce the switching losses. The power factor plays a vital issue in the usage of power electronic converters. The power oost converter and PI controller. A Simulink system is developed for 3Φ SRM by using MATLAB software. The proposed converter performance is compared with the classical converter and analysis results are presented.

Keywords- SRM, Torque Ripple, Energy Efficient, Compact power converter.

I. INTRODUCTION

In a motor the currents are switched between the different phases to keep the rotor in constant motion towards a position of minimum reluctance is known as Switched Reluctance Motor (SRM) [9].

The SRM is a singly-excited and doubly-salient machine in which the electromagnetic torque is developed due to variable reluctance principle. The motor has salient poles on both the stator and rotor but only stator carries windings [4].

The motor has no windings, magnets and cage in rotor but it is built from a stack of salient pole laminations. In order to have self-starting capability and bidirectional control the rotor of SRM has lesser poles than the stator. As rotor has no winding, a SRM is even more rugged than the rugged squirrel cage induction motor.

In SRM, though various combinations of stator pole (N_s) and rotor pole (N_r) numbers are used. The commonly used SRM motor N_s/N_r ratios are 4/2, 6/4, 8/6, 10/8 are used for 2 phase, 3 phase, 4 phase, 5 phase motor respectively [10],[12].

The shaft carries a Rotor Position Sensor (RPS). The turning ON and turning OFF of the various semiconductor devices

in the switching circuitry is influenced by the signals obtained from the rotor position sensor because the SRM is normally operated

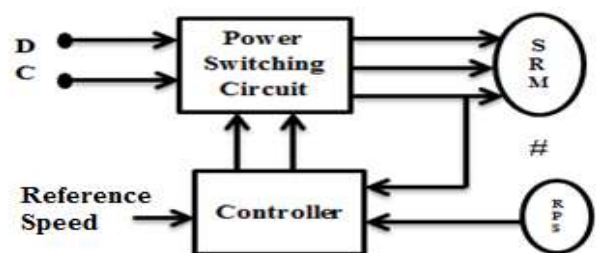

with shaft-position feedback in order to suitably excite the required phase windings with respect to precise rotor positions and general block diagram for SRM drive is shown in fig. 1.

Fig.1. General Block Diagram of SRM

II. MATHEMATICAL MODEL

The mathematical model of the Switched Reluctance Motor (SRM) is inconsistency over a complete operating region

[7]. The parameters used in SRM are changing continuously because of its highly non-linear characteristics. The SRM motor is analysis with general mathematical equations.

The SRM phase voltage can be written as

$$V = iR + \frac{d\lambda}{dt} \quad (1)$$

where, V is the DC bus voltage, i is the phase current, R is the resistance in the phase winding, iR is the ohmic drop and λ is the flux linkage.

The flux linkage λ is the function of current i and inductance L. So the equation (1) becomes

$$V = iR + \frac{d(Li)}{dt} \quad (2)$$

$$V = iR + L \frac{di}{dt} + i \frac{dL}{dt} \quad (3)$$

$$V = iR + L \frac{di}{dt} + (i \frac{dL}{d\theta} * \frac{d\theta}{dt})$$

$$V = iR + L \frac{di}{dt} + i\omega \frac{dL}{d\theta} \quad (4)$$

Where, $L \frac{di}{dt}$ is the emf due to incremental inductance, $i\omega \frac{dL}{d\theta}$ is the self-induced emf that is back emf produced by the motor and ω is the rotor speed.

The inductance of the SRM is changing continuously w.r.to the position of the rotor. The inductance profile of SRM is shown in the fig. 2.

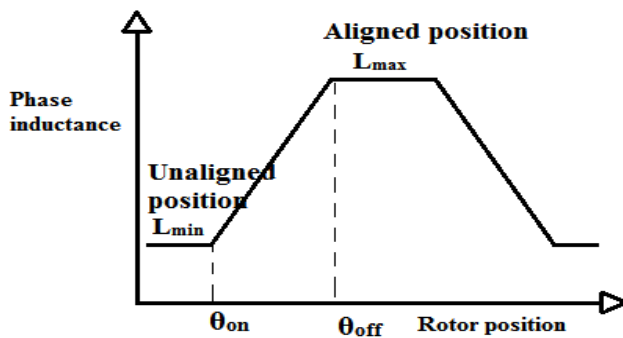

Fig. 2. Inductance profile of SRM

The rate of change of magnetic energy can be obtained by multiply current, i in the above equation and it can be written as

$$Vi = i^2R + Li \frac{di}{dt} + i^2\omega \frac{dL}{d\theta} \quad (5)$$

The magnetic energy stored can be written as

$$Wmag = \frac{1}{2} Li^2 \quad (6)$$

Rate of change of magnetic energy stored in the circuit as

$$\frac{dWmag}{dt} = \frac{d}{dt} \left(\frac{1}{2} Li^2 \right) \quad (7)$$

$$\begin{aligned} &= \frac{1}{2} L \left[2i \frac{di}{dt} \right] + \frac{1}{2} i^2 \left[\frac{dL}{dt} \right] \\ &= \left[Li \frac{di}{dt} \right] + \frac{1}{2} i^2 \left[\frac{dL}{dt} \right] \\ &= \left[Li \frac{di}{dt} \right] + \frac{1}{2} i^2 \left[\frac{dL}{d\theta} * \frac{d\theta}{dt} \right] \end{aligned}$$

$$= \left[Li \frac{di}{dt} \right] + \frac{1}{2} i^2 \omega \frac{dL}{d\theta} \quad (8)$$

Mechanical energy transferred = { Electrical energy input } - { Ohmic loss } - { Rate of change of energy stored in the magnetic field }

$$Pmech = Vi - (i^2R) - \frac{dWmag}{dt} \quad (9)$$

$$Pmech = \frac{1}{2} i^2 \omega \frac{dL}{d\theta} \quad (10)$$

The instantaneous torque T is the ratio of mechanical output power (P_{mech}) to the rotor speed (ω) and is given as

$$T = \frac{1}{2} i^2 \frac{dL}{d\theta} \quad (11)$$

From the above equation, electromagnetic torque produced in the motor is directly proportional to the square of the current and change in inductance. It is inversely proportional to the change in the rotor speed. It is also independent of the current polarity flowing in the coil.

III. PROPOSED SYSTEM

The proposed converter for SRM drive consists of the following blocks and shown in the fig.3.

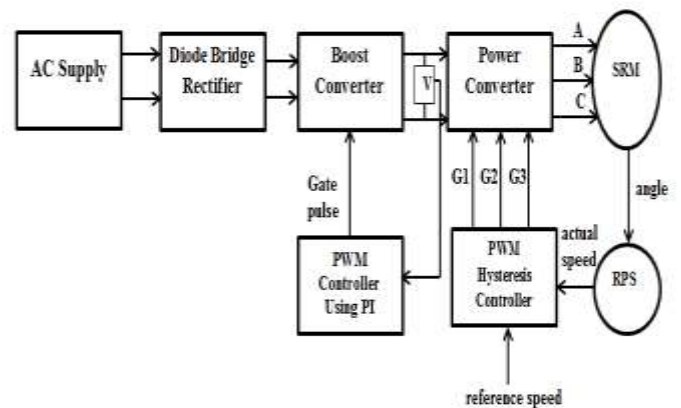

Fig. 3. Block Diagram of the Proposed System

where,

- G1,G2,G3 are Gate Pulses
- PWM- Pulse Width Modulation
- PI- Particular plus Integral Controller
- RPS- Rotor Position Sensor

They are Uncontrolled Bridge Rectifier, Soft Switching DC-DC converter, Hysteresis current controller, PI controller, Power converter, Position sensor and phase activation block and SRM model [3].

The proposed power converter is the combination of single capacitance and classic converter and the schematic diagram of the propose circuit is shown in Fig.4.

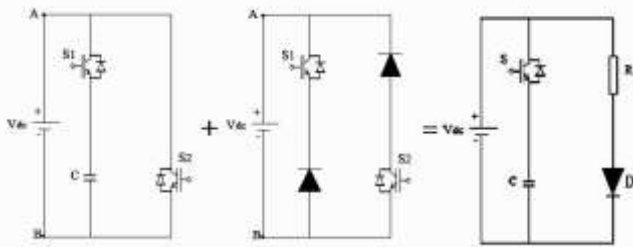

Fig.4. Schematic Diagram of the Proposed Compact Converter

The circuit consists of a capacitor C, a resistor R and two semiconductor switches, S1 and S2 connected as shown. The switches S1 and S2 are switched ON and OFF alternately, i.e. if S1 is ON, S2 is OFF and vice versa. The effective capacitance is the capacitance measured from terminals AB, which will be proven to vary with varying the duty cycle of the switching element resulting in a variable capacitance within the range between C and infinity for duty cycles of one and zero respectively.

To deduce the mathematical equations which describe the circuit operation, a current limiter should be connected to the circuit to limit the transient current value through the switches, this current limiter is a small resistor connected in series with the switching capacitance circuit [1].

The only difference which should be made when applying this circuit to an SRM motor phase is to replace the fixed inductor with a variable inductor which varies as a function of the rotor position. The circuit shown in Fig has two branches connected alternately to the supply, the first branch contains C connected in series when S1 is ON, and the second branch contains R connected in series when diode is in conduction mode.

A. Modes of Operation

The operating modes of this converter are divided into three modes. They are magnetization, demagnetization and freewheeling.

Operating modes

Mode 1: Magnetization

During the operating mode 1, the SRM phase A starts to magnetize through the switch S1 and the diode D1 when the DC voltage is applied. At the same time, the capacitor C1 in series with the switch S1 is charging. The switch S1 conducts up to current reaches its limits. During this mode, the remaining phases B & C are not in conduction.

Mode 2: Demagnetization

During this mode 2, the phase A inductance starts to demagnetize and C1 discharging. The phase B energize through the switch S2 and diode D2 and capacitor C2 starts charging. Similar to phase A & B, phase C magnetizes and demagnetizes.

Mode 3: Freewheeling

The freewheeling action takes place during demagnetize of each phase, the energy stored in the inductance and capacitor is back to the supply. During all the modes, current limiting elements perform is to limit the current through the phase winding.

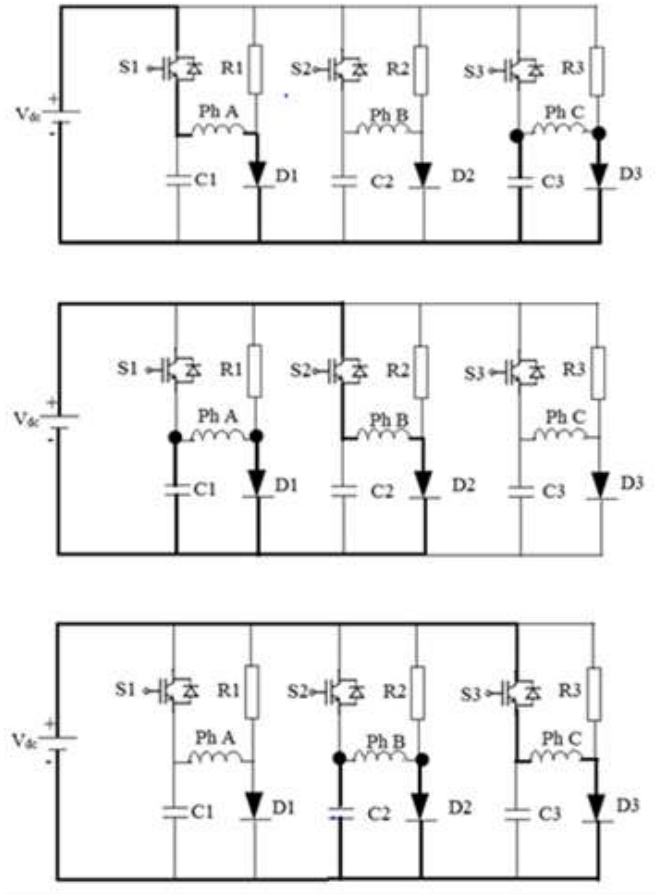

Fig.5. Operating Modes of the Proposed Compact Converter

IV. SIMULATION & RESULTS

A. Simulation of Proposed Compact Converter

The diode bridge rectifier is used to rectify the Ac input voltage 230V to the Dc output voltage [6]. The output Dc voltage has ripples and it is rectify using capacitive filter of 10μF. The output Dc is step up by using a chopper circuit. Finally the regulated 600V is given as input to the compact power converter.

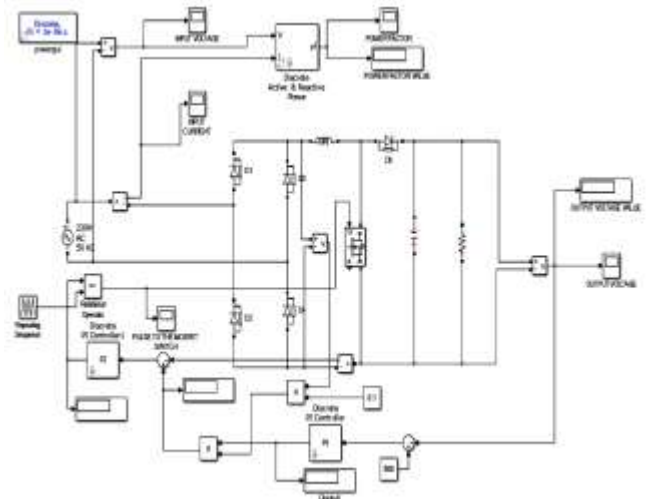

Fig. 6. Simulation Circuit of Boost Converter

In boost converter, soft switching technique is used to maintain the power factor value [5]. The MOSFET is used as switching element. The operation of this converter is detail explained in the previous chapters. The dc output voltage is step up by using the boost converter. The output is given as to generate the

input pulse to the MOSFET switch [2]. The output is given to the PI controller to get the constant voltage of 600V and is shown in the Fig. 7.

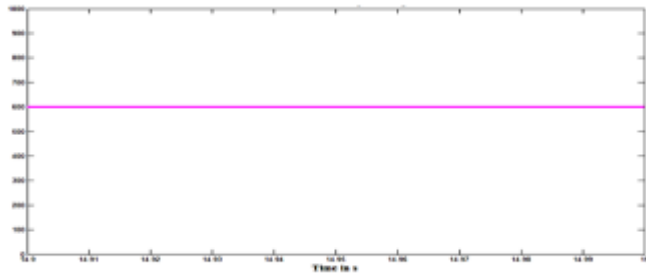

Fig. 7. Input Dc voltage to the compact converter

PI Controller 1:

$$K_p = 1 \text{ and } K_i = 0.01$$

PI Controller 2:

$$K_p = 3 \text{ and } K_i = 0.03$$

The regulated Dc voltage of 600V is given into the SRM through the compact converter is shown in the Fig. 8.

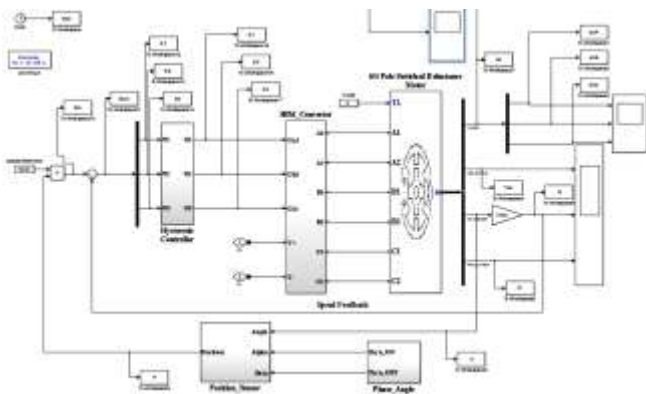

Fig. 8. Simulation circuit of Proposed Compact Converter system

The three phases of SRM are excited independently through the power converter. The hysteresis controller is used to limit the gate pulses to the IGBT switches which is used the power converter [8]. The output phase current is 10A and shown in Fig. 9. The motor specification used in the simulation is tabulated in the Table 1.

Table 1. Motor specification used in the simulation

| SINO | PARAMETERS | VALUES |
|------|--------------------------------|---------|
| 1 | Number of phases | 3 |
| 2 | Number of stator poles | 6 |
| 3 | Number of rotor poles | 4 |
| 4 | Input voltage to the converter | 600 V |
| 5 | Unaligned inductance | 0.67mH |
| 6 | Aligned inductance | 23.6mH |
| 7 | Turn on angle | 45° |
| 8 | Turn off angle | 75° |
| 9 | Rotor speed | 9440RPM |
| 10 | Output phase current | 10A |
| 11 | Electromagnetic Torque | 4 N-m |

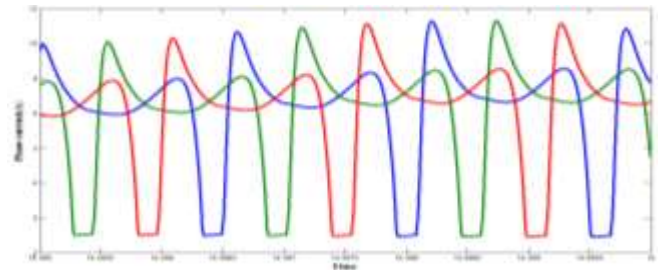

Fig. 9. Output phase current waveform

The torque ripple the proposed converter is 4 N-m. The torque ripple is considerably less compared to the classic converter. Thus it uses energy in efficient manure.

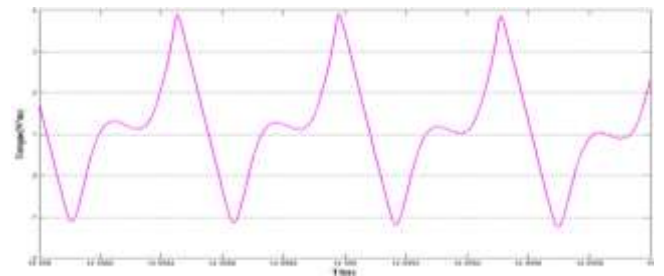

Fig. 10. Electromagnetic torque output waveform

The maximum speed of the motor is of 9440 RPM. It is also possible to obtain various speed levels within the rated speed by changing switching pattern of the converter. So, it can be used for variable speed application.

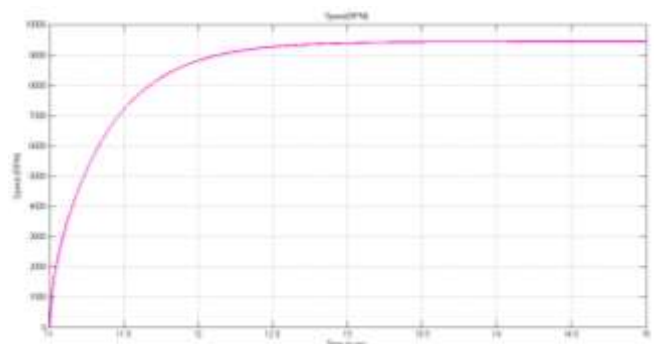

Fig. 11. Rotor Speed output waveform

B. Comparison of Proposed Compact Converter with the Classical Converter

The output waveforms of proposed converter is compared with the classical converter waveforms. The phase currents are linearly distributed to each phases in the proposed converter while the classical converter having transients current and it is shown in the Fig. 12.

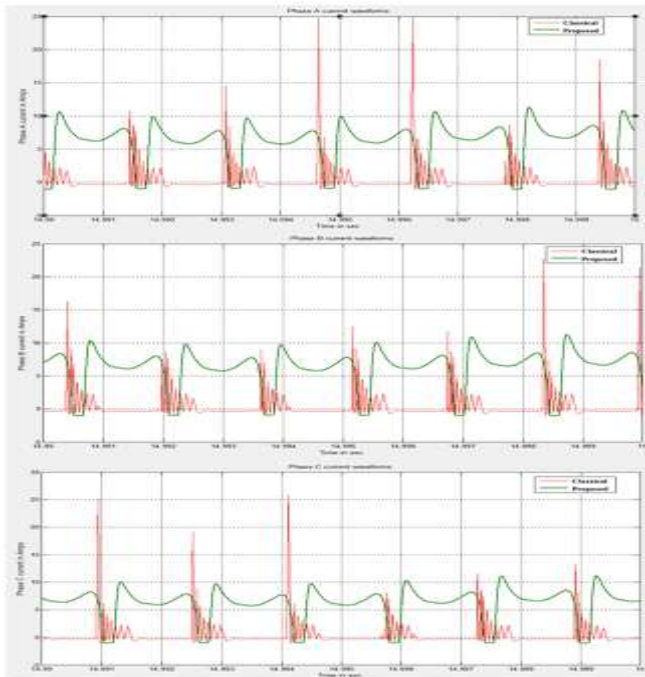

Fig. 12. Output Phase Current Analysis

The output torque ripple is highly reduced in the proposed converter and their waveforms are shown in the Fig. 13.

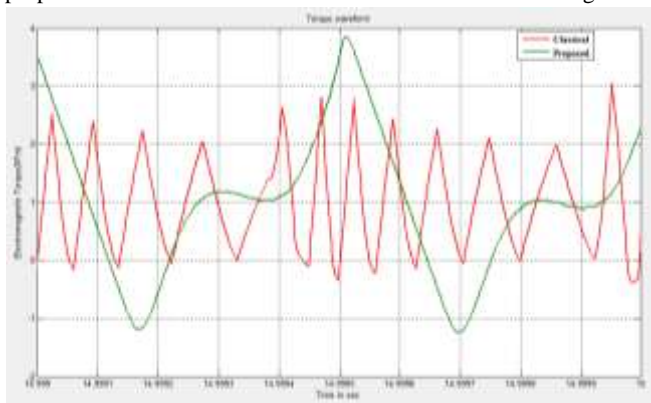

Fig. 13. Torque Ripples Analysis

The rotor speed is given in the Fig. 14. and the reference speed of the converters is set to 9440 RPM.

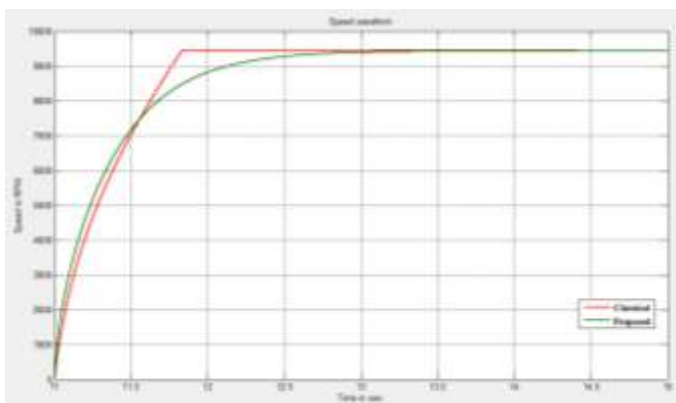

Fig. 14. Rotor Speed Analysis

Table 2. Comparison between classical and proposed compact converter

| TYPE | CLASSICAL CONVERTER | PROPOSED CONVERTER |
|----------------------|--------------------------|----------------------|
| Number of phases | 3 | 3 |
| Number of switches | 6 | 3 |
| Number of diodes | 6 | 3 |
| Commutation | Not fast enough | Fast |
| Torque ripple | Moderate | Reduced |
| Output phase current | Non linearly distributed | Linearly distributed |
| Switching losses | High | Low |
| Cost | High | Low |

The classical and proposed compact converter is compared and tabulated above. It requires less number of switches and diodes and the system as compact and reduces its cost. Its losses also half of the classical converter. It gives better performance by reducing the torque ripple and linearly distributed the output current to each phase.

V. CONCLUSION

In this work, a new compact power converter topology is proposed. The proposed power converter is excited from the chopper circuit with power factor correction by using PI controller. The proposed compact converter highly reduces the torque ripples compared with the classical converter. It also has the advantages of reduction in the logic power supplies and gate circuits, compactness in packaging, low cost and less converter losses with decrease in the heat sink volume. The power converter is simulated and compared with the conventional converter used for 3Φ SRM by using MATLAB Simulink.

REFERENCES

- [1]. Jaehyuck Kim, Keunsoo Ha, & R. Krishnan, "Single-Controllable Switch-Based Switched Reluctance Motor Drive for Low Cost, Variable-Speed Applications", IEEE Transactions on Power Electronics, Vol. 27, No. 1, pp. 379-387, Jan 2012.
- [2]. Mitulkumar R. Dave¹, K.C.Dave, "Analysis of Boost Converter Using PI Control Algorithms", International Journal of Engineering Trends and Technology- Volume 3 Issue 2- 2012.
- [3]. Hrudaya Ranjan M. and A.Srinivas, "Design and Simulation of New Power Converter for SRM Drive with Power Factor Correction" International Journal of Current Engineering and Technology, ISSN 2277 – 4106, Vol.3, No.5, Dec 2012.
- [4]. Bilgin, B., "A Novel Switched Reluctance Motor Based Propulsion Drive for Electric and Plug-in Hybrid Electric Vehicles," Chicago, Illinois: Department of Electrical and Computer Engineering, Illinois Institute of Technology, 2011.
- [5]. Neelam Rathi, Aziz Ahmed, Rajiv Kumar, "Comparative Study of Soft Switching and Hard Switching

- [6]. Dr. Ali M. Eltamaly, "*Diode Circuits or Uncontrolled Rectifier*" for EE 435- Electric Drives Lecturer notes in 2011.
- [7]. Y.-C. Cheng and C.-M. Liaw, "*On the design of power circuit and control scheme for switched reluctance generator,*" IEEE Trans. Power Electron., vol. 23, no. 1, pp. 445–454, Jan. 2008.
- [8]. H.-C. Chang and C.-M. Liaw, "*On the front-end converter and its control for a battery powered switched-reluctance motor drive,*" IEEE Trans. Power Electron., vol. 23, no. 4, pp. 2143–2156, Jul. 2008.
- [9]. R. Krishnan, S. Y. Park, and K. S. Ha, "*Theory and operation of a four-quadrant switched reluctance motor drive with a single controllable switch-the lowest cost brushless motor drive,*" IEEE Trans. IAS, vol. 41, no. 4, pp. 1047–1055, Aug. 2005.
- [10]. M. Chomat and T. A. Lipo, "*Adjustable-speed single-phase IM drive with reduced number of switches,*" IEEE Trans. Ind. Appl., vol. 39, no. 3, pp. 819–825, May/Jun. 2003.
- [11]. Krishnan, R., "*Switched Reluctance Motor Drives: Modelling, Simulation, Analysis, Design and Applications,*" Boca Raton, 2001.
- [12]. R. Krishnan, "*A novel single-switch-per-phase converter topology for four-quadrant PM brushless DC motor drive,*" IEEE Trans. Ind. Appl., vol. 33, no. 5, pp. 1154–1161, Sep./Oct. 1997.