

Enhancement of Slotted Circular Patch Antenna with Different Substrate

Ayushi Aggarwal¹, Bindia²

¹Assistant Professor, ECE Department, MAIT, Delhi

²Lecturer, ECE Department, HIT, Sonipa

Abstract:-

This paper presents the design and simulation of broadband microstrip patch antenna using High Frequency Structure Simulator (HFSS). The two different configurations of broadband microstrip patch antenna, rectangular patch antenna & circular patch antenna are analyzed. The performance of designed antennas are analyzed in terms of return loss and gain. The substrate used in these two configurations is RT Duroid having dielectric constant 2.2. The result calculated is return loss of rectangular patch & C slot rectangular patch are -10.768 db & -13.4457db and gain of rectangular patch & C shape patch are 5.6197db & 5.7457db respectively. The calculated result for return loss of circular patch & C slot circular patch are -27.7852 db & -32.4685 db and gain of circular patch & C shape patch are 11.0708 db & 11.1834db respectively.

Keywords –Rectangular Patch, Circular Patch, High Frequency Structured Simulator(HFSS).

I. Introduction

Microstrip antenna is an ideal choice for wireless communication due to low profile, light weight, low cost, simplicity of manufacturing and easy integration to circuit. However, conventional microstrip patch antenna suffers from very narrow bandwidth [1], typically about 5% bandwidth with respect to central frequency.

In recent years, there is a need of more compact antennas due to rapid decrease in size of personal communication devices. As communication devices become smaller due to greater integration of electronics, the antenna becomes a significantly larger part of the overall package volume. This results in a demand for similar reductions in antenna size. In addition to this, low profile antenna designs are also important for fixed wireless application. The microstrip antennas used in a

wide range of applications from communication systems to satellite and biomedical applications.

There are numerous and well known methods to increase the bandwidth of antenna, including increase of substrate thickness, the use of low dielectric substrate [2].

Due to evaluation of wireless communication, many high performance mobile devices are

developed which require efficient means of communication i.e. it should have low return loss & high bandwidth.

II. Antenna Design

In this section, structure of patch antennas are discussed, rectangular patch, C slot rectangular patch, Circular patch, Circular patch with C slot configuration are simulated by HFSS software in order to decrease return loss and increase gain.

A. Simple Rectangular Patch Antenna

A Rectangular patch antenna is designed and simulated here. Dimensions given in fig. 1. of patch are calculated using [3] and optimized dimensions are $L=21.388\text{mm}$, $W=20.388\text{mm}$. Substrate with dielectric constant 2.2 and height 1.588 mm, $x=3.126\text{ mm}$. Patch is designed for operating frequency 10.5 GHz. Dimension of ground plate is calculated using following equation

$$W_g = 6h + w$$

$$L_g = 6h + L$$

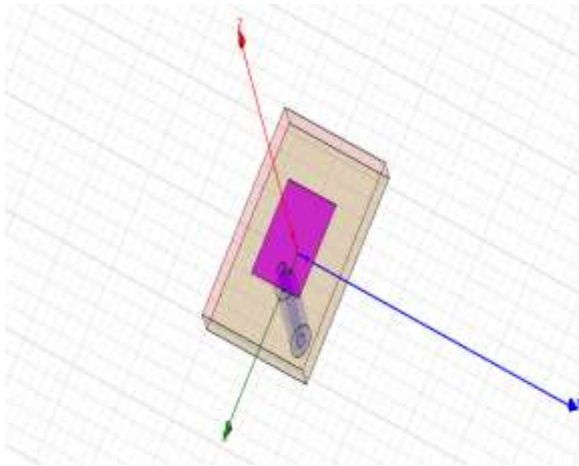

Fig 1. Top and Side view of rectangular patch antenna

After Simulation return loss is obtained - 10.768 db with gain 5.6197 db. Frequency vs Return Loss plot & radiation pattern is shown in fig. 2& fig. 3 respectively.

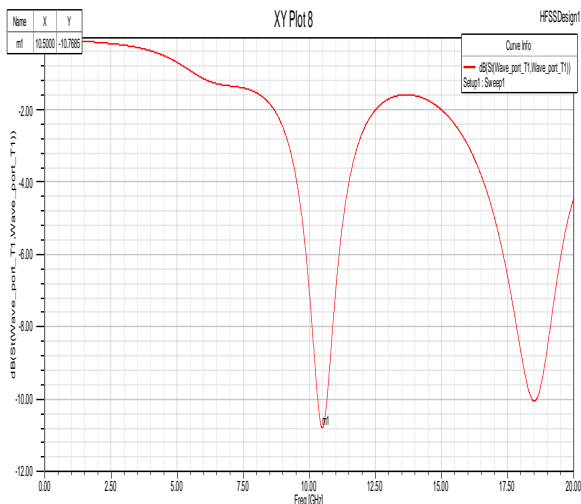

Fig 2. Frequency Vs return loss plot for rectangular patch antenna

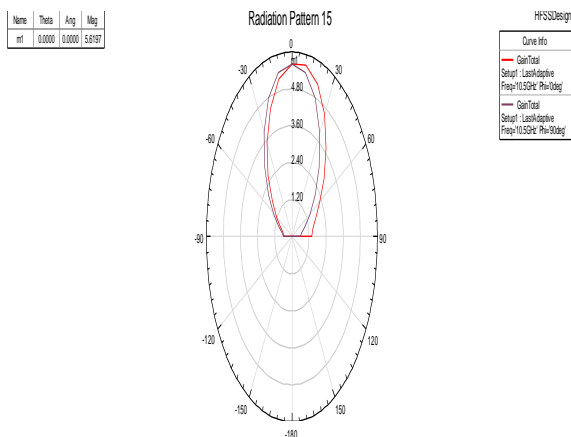

Fig 3. Radiation Pattern for rectangular patch antenna

B. C slot Rectangular Patch Antenna

C slot rectangular patch antenna is designed and simulated here.

Dimension of C slot rectangular patch is same as simple rectangular patch antenna with specific dimension 2mm & 0.5mm Patch is designed for operating frequency 10.5.

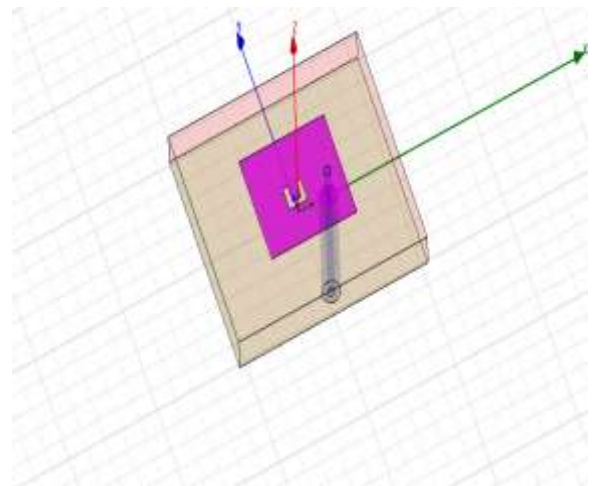

Fig 4. Top and Side view of C slot rectangular patch antenna

After Simulation return loss obtained is -13.4457 db with gain 5.7457 db. Frequency vs Return Loss plot & radiation pattern is shown in fig. 5& fig. 6 respectively.

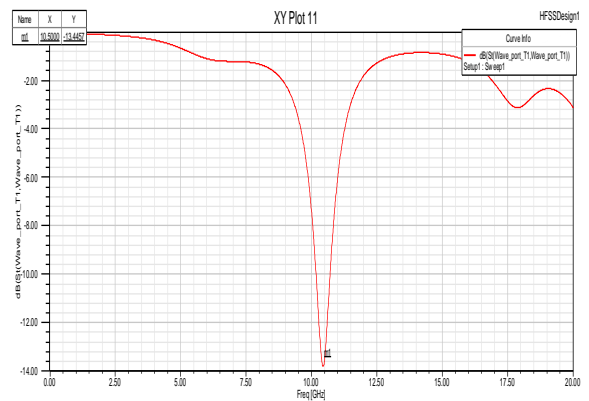

Fig 5. Frequency Vs return loss plot for C slot rectangular patch antenna

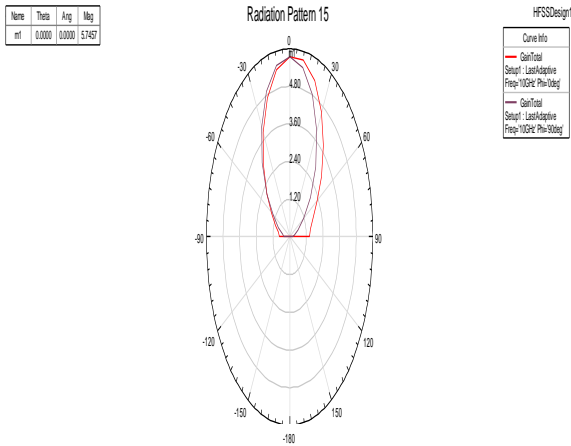

Fig 6. Radiation Pattern for C slot rectangular patch antenna

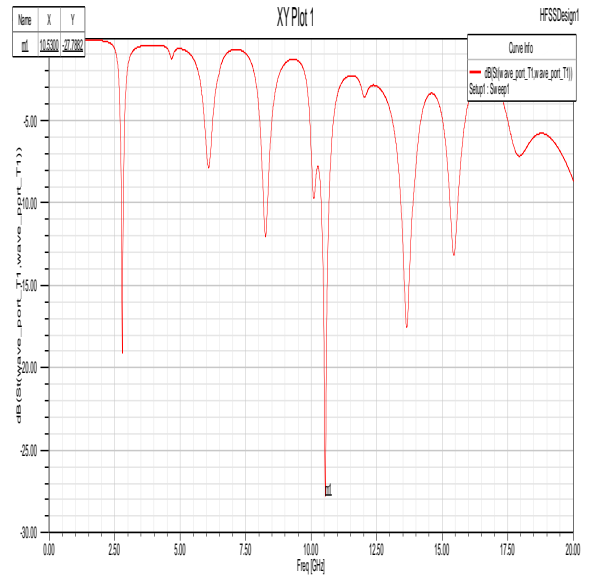

Fig.8 Frequency Vs return loss plot for Circular patch antenna

C. Circular Patch Antenna

A Circular patch antenna is designed and simulated here. Dimensions of patch are calculated using [3] and optimized dimensions are $R = 30\text{mm}$. Substrate with dielectric constant 2.2 and height 1.588 mm , $y=4.8\text{mm}$. Patch is designed for operating frequency 10.5 GHz.

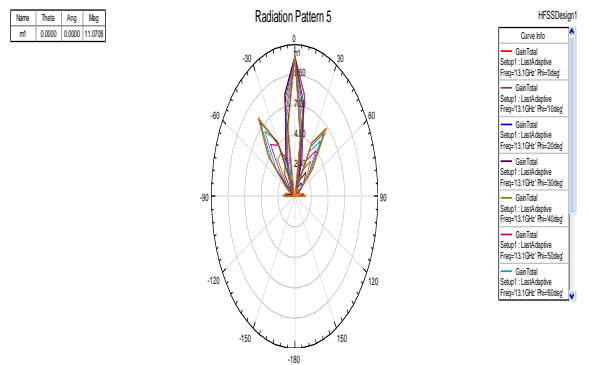

Fig. 9 Radiation Pattern for Circular patch antenna

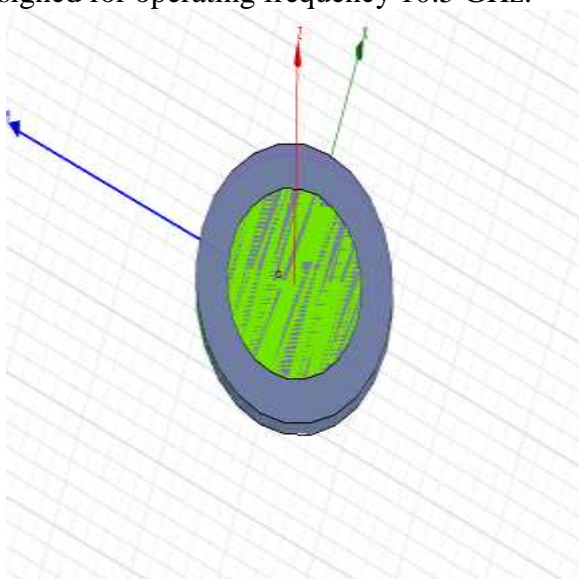

Fig 7. Top and Side view of Circular patch antenna

After Simulation return loss is obtained - 27.7852 db with gain 11.0708 db. Frequency vs Return Loss plot & radiation pattern is shown in fig. 8& fig. 9 respectively.

D. C slot Circular Patch Antenna

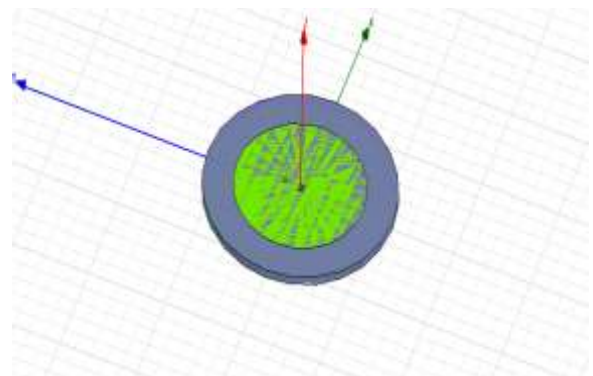

Fig. 10 Top and Side view of C slot Circular patch antenna

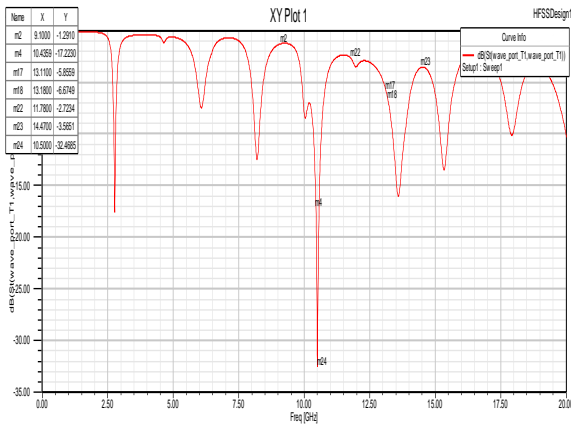

Fig 11. Frequency Vs return loss plot for C slot Circular patch antenna

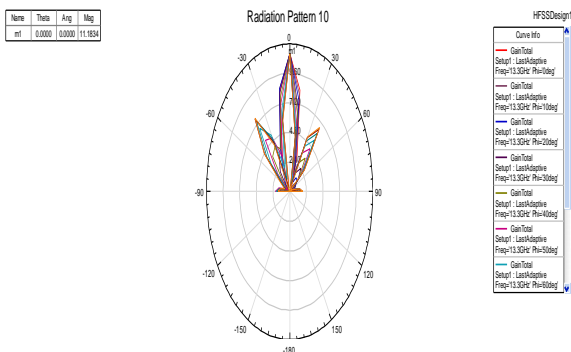

Fig.12 Radiation Pattern for C slot Circular patch antenna

III. Comparative Analysis

In this section, comparative of two configurations is shown in tabular form. Return loss and bandwidth is compared in table 1.

Table 1. Comparative analysis of different configurations of Antenna

Sr. No.	Antenna	Return loss	Gain
1.	Rectangular Antenna	-10.7689	5.6197
2.	C slot rectangular antenna	-13.4457	5.7457
3..	Circular Patch Antenna	-27.7852	11.0708
4.	Circular patch with C slot Antenna	-32.4685	11.1834

IV. Conclusion

After Simulation, it is found that Circular patch with C slot antenna has low return loss with high gain and bandwidth. Simulated return loss is -32.4685db with gain 11.1834 db.

References

1. W.He, R.Jin, and J.Gerg, "E-shape patch with wideband & circular polarization for millimeter wave communication", *IEEE Trans. Antenna Propag.*, vol 56, no 3, pp 893-895, 2008.
2. K L Lau, K.M Luk and K.L Lee, "Design of Circularly- Polarized Vertical Patch Antenna," *IEEE Trans. Antenna Propag.*, vol 54, no 3, pp 1332-1335, 2006
3. Milligan T, *Modern Antenna Design*, John Wiley & Sons, 2005.
4. Malekoo H & Jam S, "Miniaturized asymmetric E shaped Microstrip patch antenna with folded patch feed", *IET Microwave Antenna & propagation*, 2013.
5. Ali M.T., Aizat, Pasya I., Zaharuddin M.H.M. & Yaacob N, "E shaped Microstrip patch antenna for wideband Application", *IEEE International RF & Microwave conference, Malaysia*, 2011.
6. M. T. Ali, A. Aizat, I. Pasya, M. H. Mazlan Zaharuddin and Norsuzila Ya'acob, "E-shape Microstrip patch Antenna for Wideband Applications", *IEEE International Conference on RF and Microwave*, pp. 439-443, 2011.
7. Hang wong, Kwai-Man luk, Chi Hou Chan, Quan Xue, Kwok Kan So and Hau Wah Lai, "Small antennas in wireless communications", *Proceedings of the IEEE*, Vol. 100, No. 7, pp. 2109-2121, 2012.
8. Garg R, Bhartia P, Bahl I, Ittipiboon A, *Microstrip Antenna design handbook*, Artech House London, 2001.
9. Balanis C.A, *Antenna Theory & Analysis*, John Wiley & Sons, 2007.
10. Ansys Inc. "High Frequency Structural Simulator (HFSS) Software" version -13