

Combination of Modified Clipping Technique and Selective Mapping for PAPR Reduction

R. SHIVAJI, *M.tech, (Ph.D)*¹ **PATNAM GAYATHRI** (*M.tech.*)²

¹*Assistant professor, Vijay Rural Engineering College, Nizamabad, Telangana, 503003, INDIA*

²*Department of ECE, Vijay Rural Engineering College, Nizamabad, Telangana, 503003, INDIA*

shivaji147@gmail.com gayathripatnam@gmail.com

Abstract

Orthogonal frequency division multiplexing (OFDM) offers high data rate and supports high data rate applications. Although OFDM has advantages over traditional communication models but it frequently suffers from PAPR. PAPR is concerned area in OFDM from two decades and vast amount of research is carried out in literature. Selective Mapping remains as effective PAPR reduction approach and in proposed method a modified clipping technique along with selective mapping is used to reduce the PAPR reduction in efficient way. Experimental shows better results over traditional state of art methods.

Keywords: PAPR, OFDM, Modified clipping technique, Selective Mapping

1. INTRODUCTION

Orthogonal frequency division multiplexing (OFDM) and compatible usage in wireless standards like DVB, WIMAX, IEEE802.11a and LTE has been gained interest from worldwide research organizations. Recently an international meeting has conducted in order to discuss importance of orthogonal frequency division multiplexing (OFDM) and its usage in advance wireless standards makes Orthogonal frequency division multiplexing (OFDM) as an emerging technology to meet the requirements in practical scenario. Orthogonal frequency division multiplexing (OFDM) has high data rates compared to traditional communications systems and it suited well for frequency selective channels. Large delay

spreads is a drawback which commonly occurs in the high speed wireless communication system and orthogonal frequency division multiplexing (OFDM) modulation scheme has ability to transform the wide frequency selective channel to narrow ones which creates the robust environment to resists against occurrence of the large delay spreads and preserves the Orthogonality in perfect way in the frequency domain. Orthogonal frequency division multiplexing (OFDM) has one more unique advantage to reduce the complexity in the system by introducing the cyclic prefix at the transmitter end and performing scalar equalization at the receiver end in the wireless standards like WIFI and WIMAX [1].

In 21st century, the role of the technology to offer high data rates and mobility is crucial and the technology is changing its face every other because of immense research work carried out on the advance wireless communications. Actually the research on parallel data transmission is traced out in the mid 1960's but it takes 25 long years to make it compatible to real time applications. The OFDM gradually seen its presence in the various application and now various international standards consider it as promising modulation scheme which initially supports wireless standards like WIFI, WIMAX, LTE etc. The two important parameters required better transmission of data from one entity to another are data rate and the modulation scheme should support different channel conditions to obtain better spectral efficiency.

Transmission of the digital data through multipath environments has been considered as area of concern in the future wireless communication system. Advancement in the technological aspects paves way to design an advance modulation scheme namely orthogonal frequency division multiplexing (OFDM). Orthogonal frequency division multiplexing (OFDM) modulation scheme has ability to transmit the information through multipath environments [2]. The bandwidth utilization is called as spectral efficiency and the bandwidth occupied by the orthogonal frequency division multiplexing (OFDM) is directly relates to transmission data rate. The commonly occurred question arise in the orthogonal frequency division multiplexing (OFDM) modulation scheme is how to obtain better diversity levels and mitigating the loss of signal in adverse fading environments

2. PAPR REDUCTION TECHNIQUES

In literature different PAPR reduction has reported to improve the efficiency of the system in th transmitter medium and successfully removes the noise related content from the transmission line. Some of the popular PAPR reduction techniques are reviewed in this section

2.1 PARTIAL TRANSMIT SEQUENCE

Diminishing the PAPR to improve the efficiency at the transmitter end has been considered as the concerned area from two decades. Partial transmit sequence (PTS) is a popular and most efficient PAPR reduction scheme which is designed to diminish the PAPR impact from OFDM system.

The design behind the partial transmit scheme is based how efficiently the sub block division is performed from the original OFDM signal. Another new thing implemented in this approach is phase rotation which helps the candidate to choose the signal with the lowest PAPR. Original OFDM sequences are divided into disjoint symbol subsequence by using the partition process and in the latter step each subsequent subcarrier is applied by IFFT and another process named distinct rotating vectors is used to make sum of all blocks after multiplied by using the rotating vectors in efficient way.

2.2 TONE RESERVATION APPROACH

Till now various PAPR reduction have proposed in the literature but majority of the schemes are approximate while tone reservation approach is an accurate scheme proposed to diminish PAPR in effective manner. The idea behind the tone reservation approach is to design a reliable system to control the PAPR impact on the OFDM transmitter side.

The important factors used to mitigate PAPR impact in OFDM modulation scheme are reserved tones locations, complexity levels, reserved tones power and number of reserved tones. The beauty of the tone reservation approach is controlling the large amount of PAPR using small tones which decreases run time complexity and increases performance drastically. In traditional schemes additional operations and information needs to include at the receiver end while in the tone reservation approach no side information and no additional operation is required at receiver end. The design of tone reservation approach is based on the data block summation and signal in terms of time domain. The data block helps in minimizing high PAPR based on original multi carrier signal and note that data block which is used in this approach are termed as the depended block signal.

2.3 PEAK CANCELLATION

The constellation region is the important factor which represents notates the data symbol points and in this algorithm both amplitudes and phase statistics are taken into consideration to keep the peak value in the limited. Various constellation approaches are reported in the literature and in that QPSK constellation is used for constellation approach. The idea behind QPSK constellation approach usage is to get four different values of QPSK symbol.

2.4 PEAK WINDOWING

The idea behind the window technique is to diminish the larger PAPR with peak windowing and the PAPR reduction process done with little interference. This algorithm proposes an approach to mitigate PAPR at the cost of increasing BER and OFB (out of bands) radiation. Various windowing techniques are

employed in peak windowing algorithm as Gaussian shaped window, Kaiser, cosine, and hamming window with results in convolution of spectrum window and OFDM spectrum.

3. PROPOSED METHOD

To achieve a better PAPR performance, we propose a modified clipping technique in this section. Unlike the conventional clipping approach, where the clipping criteria are made on the basis of a single threshold value, we adopt two thresholds. If the signal amplitude is higher than the upper threshold value, the signal will be clipped down to the upper level. On the other hand, if the signal amplitude is below the lower threshold value, it will be enhanced to reach the lower clipping level. In this way, PAPR of the signal can be improved. The concept of proposed modified clipping is explained.

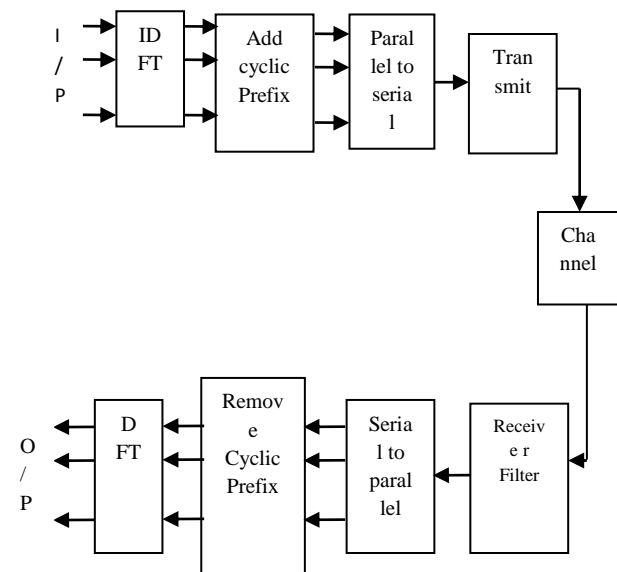

Figure 1: Figure 1: Proposed method

The proposed modified clipping can be expressed as:

$$\hat{x}(t) = \begin{cases} CLHe^{j\phi(t)} & |\bar{x}(t)| > CLH \\ \hat{x}(t) & CLL < |\bar{x}(t)| < CLH \\ CLLe^{j\phi(t)} & |\bar{x}(t)| < CLL \end{cases} \quad (1)$$

In this equation, ‘CLH’ denotes the upper threshold level, ‘CLL’ is the lower threshold level, and $\bar{x}(t)$ represents the input OFDM signal. To further improve the PAPR performance, we then combine the conventional selective mapping (SLM) with the modified clipping technique. As SLM improves PAPR and control BER, the proposed joint technique may also improve the PAPR relying on the SLM based modified signal, thus further improving the PAPR reduction. The block diagram of the proposed joint technique is shown in Figure 1

4. RESULTS

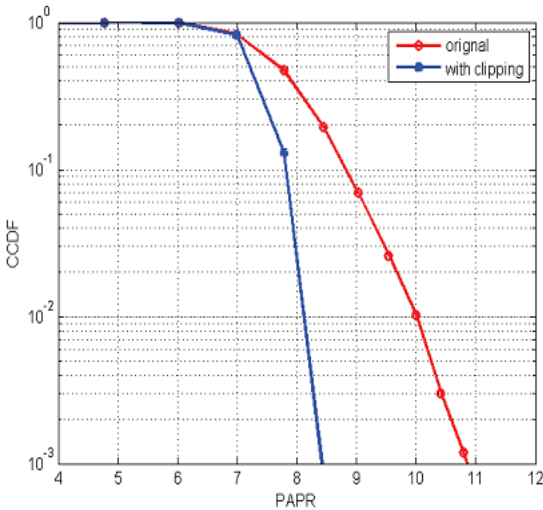

Figure 2: Comparison of original OFDM signal with conventional clipping

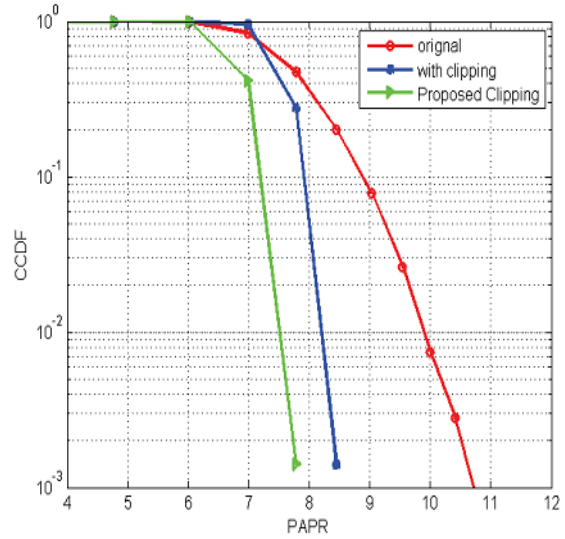

Figure 3: Comparison of conventional clipping with modified clipping

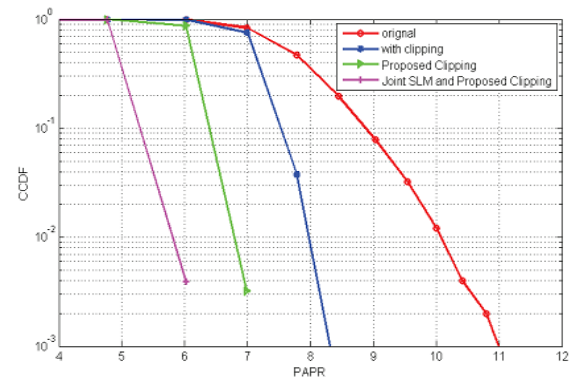

Figure 4: Comparison of proposed scheme with modified clipping and conventional clipping

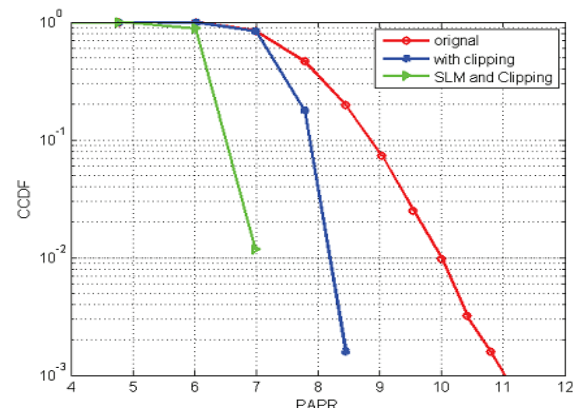

Figure 5: Comparison of Joint SLM and conventional clipping with conventional clipping

5. CONCLUSION

The proposed method achieves better performance and low runtime complexity when compares existing SLM based PAPR reduction approach. A modified clipping technique along with selective mapping is proposed as proposed algorithm for PAPR reduction approach. PAPR reduction task in OFDM systems has become a challenging task, and various techniques have been suggested previously to achieve this task. Simulation results show that the modified clipping approach improves the PAPR performance compared to the traditional clipping approach.

REFERENCES

- [1] R. V. Nee and R. Prasad, OFDM for Wireless Multimedia Communications. Artech House Publisher, 2000
- [2] X. and Li and L. J. C. Jr., “Effects of Clipping and Filtering on the Performance of OFDM,” IEEE Commun. Lett., vol. 2, no. 5, pp. 131–133, 1998
- [3] Y. Rahmatallah and S. Mohan, “Peak-To-Average Power Ratio Reduction in OFDM Systems : A Survey And Taxonomy,” IEEE Comun. Surv. Tutorials, vol. 15, no. 4, pp. 1567–1592, 2013
- [4] K. Sultan, H. Ali, and Z. Zhang, “Improving PAPR Reduction for OFDM using Hybrid Techniques,” in 2015 Internation Conference on Communication Software and Networks (ICCSN), 2015, pp. 312–316
- [5] H. Ochiai and H. Imai, “Performance analysis of deliberately clipped OFDM signals,” IEEE Trans. Commun., vol. 50, no. 1, pp. 89–101, 2002
- [6] H. Ochiai and H. Imai, “On the Clipping for Peak Power Reduction of OFDM signals,” in IEEE Global Communications Conference (CLOBECOM), San Francisco, USA, 2000, pp. 731 –735
- [7] J. Armstrong, “Peak-to-Average Power Reduction for OFDM by repeated clipping and frequency domain filtering,” IEE Electron. Lett., vol. 38, no. 5, pp. 246 –247, 2000
- [8] J. Armstrong, “Peak-to-average power reduction for OFDM by repeated clipping and frequency domain filtering,” IEE Electron. Lett., vol. 38, no. 5, pp. 246–247, 2002
- [9] A. Kubo, A. S.Tomisato, and M.Hata, “Transmission performance of highly efficient OFDM signals with iterative peak reduction,” in AsiaPacific Conference on Wearable Computing Systems (APWCS), 2005, pp. 145–148
- [10] T. Jian and P. Li, “An Improved SLM method for PAPR Reduction in OFDM systems,” in IET 3rd International Conference on Wireless, Mobile amd Multimedia Networks (ICWMNN 2010), 2010, pp. 242 – 246