

The Performance Analysis of OFDM-IDMA in Wireless Communication by Using an Iterative Sub-optimal Receiver Structure

Y.Sukanya¹, K.Lakshmana Rao²

¹ Dept. Of Electronics And Communication
 Vignan's institute of information technology
 Visakhapatnam, India
sukanya_ece@rediffmail.com

² Dept. Of Electronics And Communication
 Vignan's institute of information technology
 Visakhapatnam, India
Laxman433@gmail.com

Abstract: This paper provides a comprehensive study of OFDM-IDMA. Comparisons with other alternative technology such as OFDM-CDMA are provided. Cyclic Prefix reduces the ISI in the OFDM Block and MAI is reduced by IDMA in the AWGN channel. A signal-to-noise ratio (SNR) evolution technique is developed to predict the bit-error-rate (BER) performance of OFDM-IDMA by using BPSK modulation. Also, we provide simulation results in the matlab environment.

Keywords: AWGN, CDMA, CP, FFT, IFFT, IDMA, OFDM, and OFDM-IDMA.

1. Introduction

Multiple access schemes are used to allow many mobile users to share simultaneously a finite amount of radio spectrum. The sharing of spectrum is required to achieve high capacity by simultaneously allocating the available bandwidth to multiple users. IDMA (Interleave Division Multiple Access) is the extension of CDMA[1]. All users in a CDMA system use the same carrier frequency and may transmit simultaneously. A conventional random waveform CDMA (RW-CDMA) system involves separate coding and spreading operations. So, the whole bandwidth is used by coding. In this case, interleavers can be employed to distinguish signals from different users[2]. Due to AWGN channel Multiple Access Interference (MAI) and Inter Symbol Interference (ISI) are major sources of impairments in wireless communication systems. OFDM-IDMA can be resolved interference. The cost of Conventional multi user detection (MUD) is very high. OFDM (Orthogonal Frequency Division Multiplexing) is a multi carrier modulation technique. OFDM transmits data in parallel by modulating a set of orthogonal sub carriers. The carriers have minimum frequency separation required to maintain orthogonality. In Multiple carrier modulation inter symbol interference occurred due to channel. By using cyclic prefix in the OFDM can achieve the inter symbol interference[8]. OFDM-IDMA system inherits so many advantages of OFDM-CDMA that it can effectively deal with ISI and reduce

interference between cells. The output of IDMA is very high because it uses one simple and effective Turbo iterative for MUD algorithm, on the other hand, OFDM-IDMA doesn't need spectrum spreading because its users are differentiated by

interleavers, so the whole band spreading of system can be used for FEC to get higher gain.

2. Transmitter

OFDM-IDMA transmitter is shown in Fig .1. The transmitter structure of the multiple access scheme under consideration with M simultaneous users. The input random data sequence $\mathbf{a}_m = [a_m(1), a_m(2), a_m(3) \dots \dots a_m(L)]^T$ of user-*m* is encoded based on a low-data rate code C. It generates a coded data sequence $\mathbf{c}_m = [c_m(1), c_m(2), \dots \dots c_m(n), \dots \dots c_m(N)]^T$, where *N* is the frame length. The elements in \mathbf{c}_m is permuted by an interleaver π_m , producing $\mathbf{x}_m = [x_m(1), x_m(2), \dots \dots x_m(j), \dots \dots x_m(I)]^T$. After encoding users are separated by their interleavers.

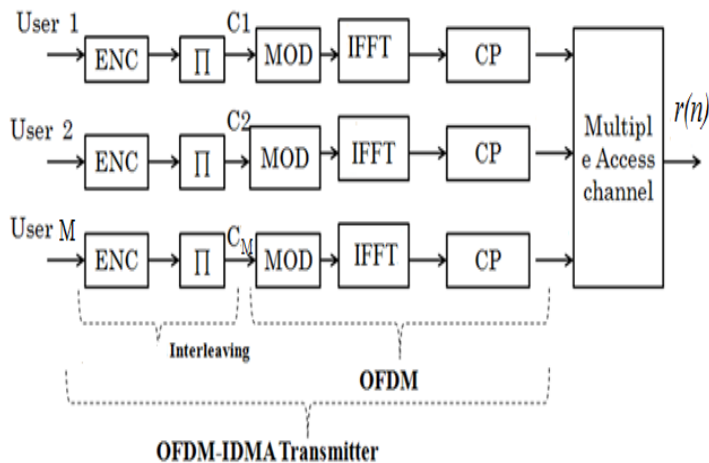

Figure 1:OFDM –IDMA Transmitter

2.1. Mechanism Of Interleaving Process

The advantage of IDMA is that the interleavers π_m should be different compare to other users. This is the principle of IDMA. Here, we assume that the interleavers of different users are generated randomly and independently. The adjacent chips are approximately uncorrelated because these interleavers disperse the coded sequences [2].

$$\pi_m = [\pi_m(1), \pi_m(2), \dots, \pi_m(n), \dots, \pi_m(N)]^T$$

The interleaver is termed as a mechanism which rearranges the ordering of a data sequence by means of a deterministic bijective mapping. Let

$C_m = [c_m(1), c_m(2), \dots, c_m(n), \dots, c_m(N)]^T$ be a sequence of length N . An interleaver maps C onto a sequence

$X_m = [x_m(1), x_m(2), \dots, x_m(n), \dots, x_m(N)]^T$ such that X is a permutation of the elements of C . Considering C and X as a pair of N -dimensional vectors, there is one-to-one correspondence $c_i \rightarrow x_j$ between each element of C and each element of X , as shown in Figure 2.

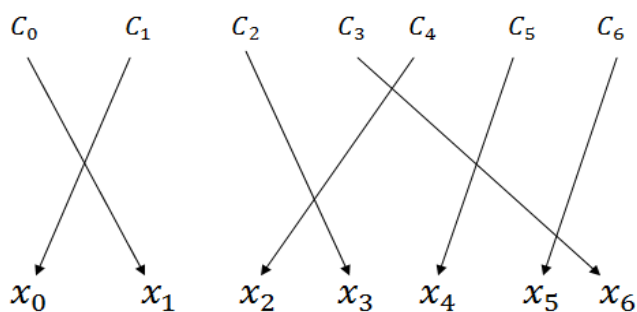

Figure 2: Mechanism of Data Interleaving

An interleaver can then be defined by the one-to-one index mapping function. Original sequence ‘ C ’ and the interleaved sequence ‘ X ’, respectively. The mapping function can be expressed as an ordered set called interleaving vector ‘ π ’ $\pi_n = [\pi_n(1), \pi_n(2), \dots, \pi_n(n), \dots, \pi_n(N)]^T$.

The n^{th} element of the permuted sequence X is $X^n = C^{\pi[n]}$. The interleaver sequence is mapped by using BPSK modulation. Because BPSK has less bit-error-rate compare to

other psk modulation techniques in AWGN channel. BPSK mapped bits are shown below fig.3.,

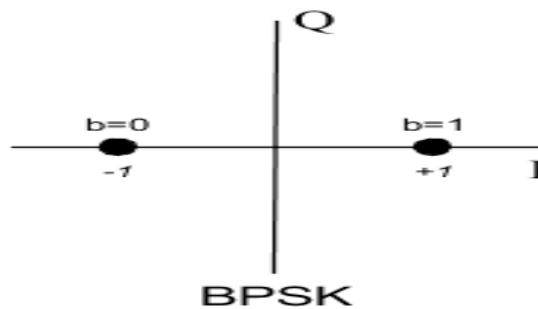

Figure 3:BPSK Mapping

2.2. Inverse Fast Fourier Transform

Orthogonality property is applicable in the IFFT. The modulation output is in the frequency domain. IFFT converts the signal from frequency domain to time domain. In the OFDM transmission system, N -point IFFT is taken for the transmitted bits $\{X[k]\}_{k=0}^{N-1}$, so as to generate

$\{x[n]\}_{n=0}^{N-1}$, the samples for the sum of N orthogonal sub carriers[8]. The FFT algorithm reduces the

number of complex multiplications $\frac{N}{2} \log_2 N$ and additions $N \log_2 N$.

The N -point IDFT of $x(n)$ can be written as

$$x(n) = \frac{1}{N} \sum_{k=0}^{N-1} X(k) e^{j2\pi nk/N}, \quad 0 \leq n \leq N-1$$

3.3. Cyclic-Prefix (CP)

To avoid inter symbol interference in AWGN channels, a CP of length N_{cp} is inserted prior to the OFDM block. During this interval, a cyclic prefix is transmitted such that the signal in the interval $-N_{cp} \leq n < 0$ equals the signal in the interval $(N - N_{cp} \leq n < N$. The OFDM signal with cyclic prefix is thus[9] shown in fig.4.:

$$x(n) = \frac{1}{N} \sum_{k=0}^{N-1} X(k) e^{j2\pi nk/N}, \quad -N_{cp} \leq n < N$$

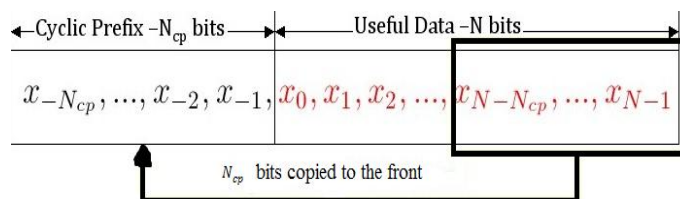

Figure 4: Cyclic-prefix

3. Additive White Gaussian Noise Channel

In communication theory it is often assumed that the transmitted signals are distorted by some noise. The most common noise to assume is additive Gaussian noise, i.e. the so called Additive White Gaussian Noise channel, AWGN. Even though the noise in reality is more complex, this model is very efficient when simulating for example background noise or amplifier noise.

4. Iterative receiver

Assume that channel has no memory. The received signal $r(n)$ from M users can be written as

$$r(n) = \sum_m h_m(n)x_m(n) + Z(n),$$

$n=1, \dots, N$

Here $Z(n)$ are samples of AWGN process with variance $\sigma^2 = E_0/2$. h_m is channel coefficients. It is priori at the receiver. At the receiver cyclic prefix length N_{cp} is removed prior to the OFDM block. To process the signal FFT is used to convert time domain to frequency domain.

N -point DFT is written as

$$R(k) = \frac{1}{N} \sum_{n=0}^{N-1} r(n)e^{j2\pi nk/N}, \quad 0 \leq k \leq N-1$$

The problems of multiple access and encoding limits can be figured out by chip-by-chip detection and decoders, the output of chip-by-chip detection and decoders is LLRs about $\{x_m(k)\}$, that is we usually called extra information[6]. Chip-by-Chip detection and decoders are shown in fig .5.:

$$e(x_m(n)) = \log \left[\frac{P(y/(X_m(n)) = +1)}{P(y/(X_m(n)) = -1)} \right] \dots\dots\dots(1)$$

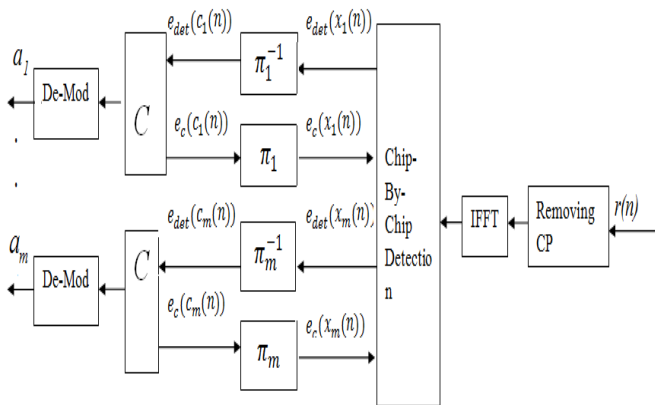

Figure 1: OFDM-IDMA Iterative Receiver

$$\mathcal{R}(k) = \sum_{m=1}^M \mathcal{H}_m X_m(k) + \xi_m(k) \dots\dots\dots(2)$$

Where,

$$\begin{aligned} \xi_m(k) &= \mathcal{R}(k) - \mathcal{H}_m X_m(k) \\ &= \sum_{k' \neq k} \mathcal{H}_{m'} X_{m'}(k) + \mathcal{N}(k) \dots\dots\dots(3) \end{aligned}$$

is the distortion (including noise and interference) in $\mathcal{R}(k)$ with respect to M^{th} user. According to central limit theorem

the sum of a large number of random variables can be characterized by a conditional Gaussian probability density function[3].

$$\mathcal{P} \left(\frac{\mathcal{R}(k)}{x_m(k)} = \pm 1 \right) \dots\dots\dots(4)$$

4.1. Chip-by-Chip detection algorithm

Step(i): Set $e_c(x_m(k)) = 0$,Initially

Step(ii):1. Estimate the mean and variance of $\mathcal{R}(k)$ received signal using equation(1).

Expected value of $\mathcal{R}(k)$ is Mean $\mathcal{E}(\mathcal{R}(k))$ and variance is $Var(\mathcal{R}(k))$

2. Estimate the mean and variance of $\xi_m(k)$ distortion using equation (3).

Step(iii): Log-likelihood ratio

From equation (1) and (4)

$$e_{det}(x_m(n)) = 2H_m \cdot \frac{\mathcal{R}(k) - \mathcal{E}(\xi_m(k))}{Var(\xi_m(k))}$$

Step (iv): From equation (1) e_c and $X_m(k)$ are extrinsic LLRs .So the mean $\{ \mathcal{E}(X_m(k)) \}$ and variance

$\{Var(X_m(k))\}$ are used to generate and update for every user.

5. Performance analysis

5.1. Simulation Parameter:

In this simulation, number of users are 4, number of input random bits are 1024, spreading sequence is 16, FFT length and number of carriers are 1024, number of input random bits are 1024, cyclic prefix is 32, All the users use the same spectrum spreading code sequence: $s=\{+1,-1,+1,-1,\dots\}$ with the same length 16, the chip interleaver assigned to each user is randomly output by the system. Fig.4 depicts the performance of OFDM-IDMA for multi-users in AWGN channel; it is shown that without energy distribution, the performance of system with different users is still close to the performance with one user with increasing SNR, so the system shows the better performance for multiple users.

5.2. Performance analysis

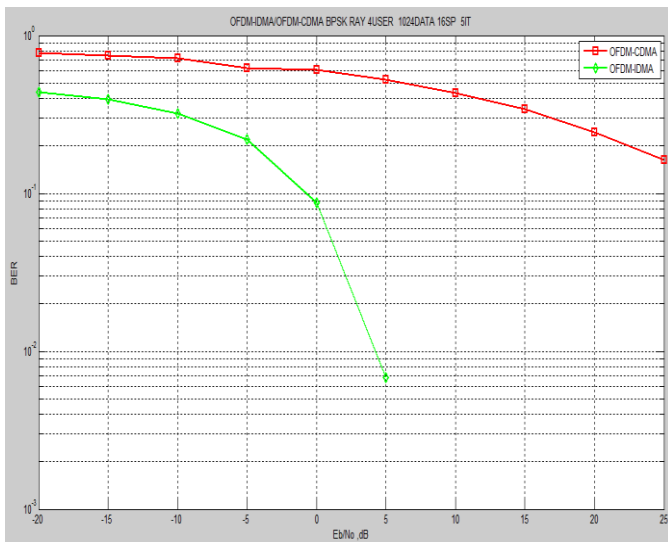

Figure 6: Performance analysis of User 1

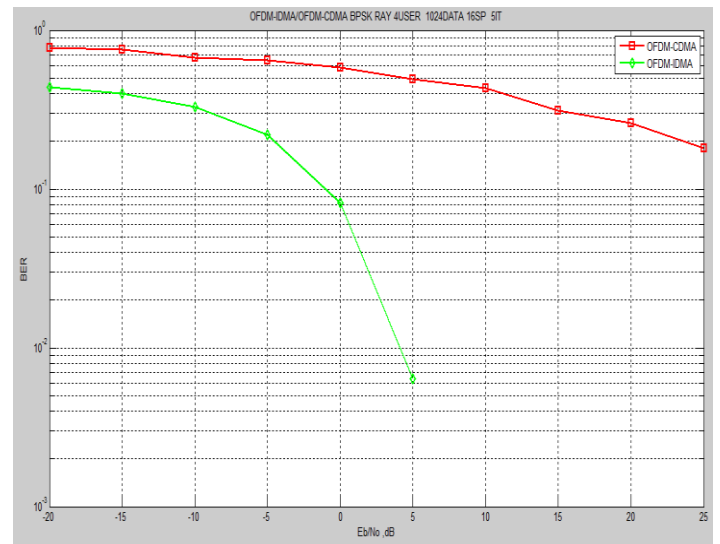

Figure 1: Performance analysis of User 4

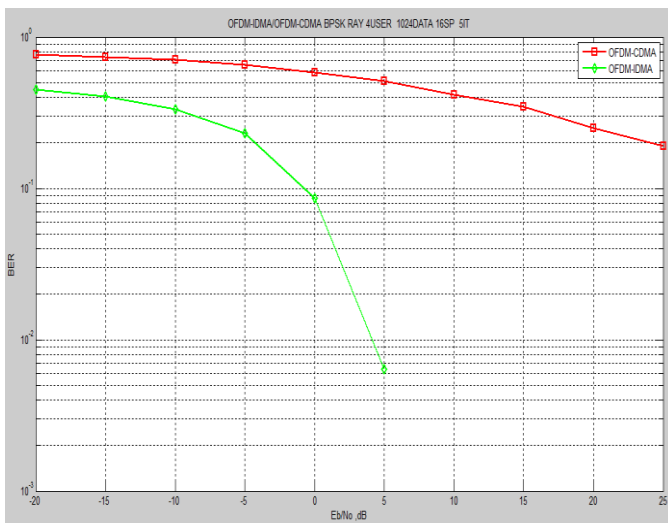

Figure 7: Performance analysis of User 2

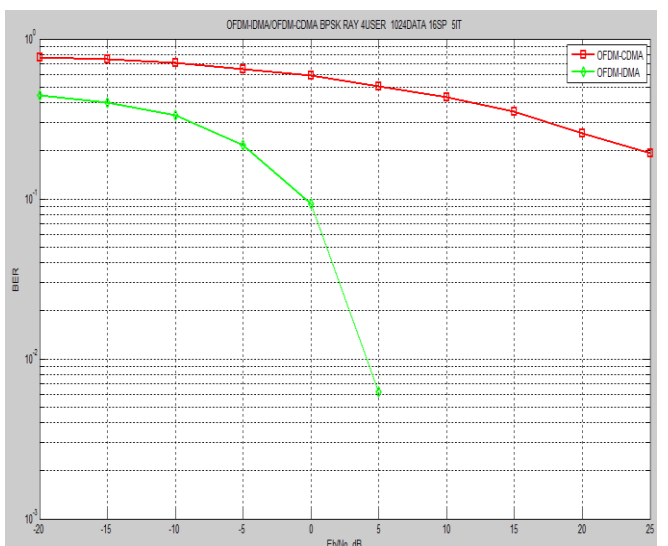

Figure 1: Performance analysis of User 3

Above figures (6, 7, 8 & 9) show the performance analysis of OFDM-IDMA and OFDM-CDMA with different users. Figure shows the OFDM-IDMA has best performance compare to OFDM-CDMA.

6. Conclusions

OFDM-IDMA system structure based on theory of OFDM and IDMA is constructed in this paper, simulation results in AWGN channel all show that OFDM-IDMA system inherits all the advantages of OFDM and IDMA, it shows better performance than traditional multiple access technology, especially with larger users, it has more simple multi-user iterative detection algorithm and lower complexity. In a word, OFDM-IDMA based on multi-carrier modulation and interleaving multiple access technology will draw more attention in the future wireless communication. OFDM-IDMA shows the better performance compare to OFDM-CDMA.

REFERENCES

- [1] Theodore, S. Rappaport, "Wireless Communications, Principles, Practice" -, PHI, 2nd Edn., 2002.
- [2] LI Ping, LIU L, WU K Y, et al. Interleave-division multiple access [EB/OL].
- [3] LI Ping, LIU L H, WU K Y, et al. Interleave division multiple access (IDMA) communication systems [C] // Proc. 3rd International Symposium on Turbo Codes & Related Topics, . 2003: 2157-2161.
- [4] LI Ping. Interleave-division multiple access and chip-by-chip iterative multi-user detection [J]. Communications Magazine, IEEE, 2005, 43(6): S19- S23.
- [5] OFDM and MC-CDMA for Broadband Multi-user Communications, WLANs and Broadcasting by L. Hanzo, M. M'ünster, B.J. Choi and T. Keller.
- [6] C. Berrou and A. Glavieux, "Near optimum error correcting coding and decoding: Turbo-codes," *IEEE Trans. Commun.*, vol. 44, pp. 1261-1271, Oct. 1996.
- [7] L. Liu, W. K. Leung, and Li Ping, "Simple chip-by-chip multi-user detection for CDMA systems," in *Proc. IEEE VTC'2003-Spring*, Jeju, Korea, Apr. 2003, pp. 2157-2161.
- [8] Fazel K, Kaiser S. Multi-Carrier and Spread Spectrum Systems. John Wiley Sons: Chichester, UK, 2003.

- [9] MIMO-OFDM Wireless Communications with matlab, / Yong Soo Cho ... [et al.], p. cm. Includes bibliographical references and index. ISBN 978-0-470-82561-7 (cloth).

[10] Multi-Carrier Digital Communications Theory and Applications of OFDM Second Edition, Ahmad R.S., Saltzberg, Burton R., Ergen, Mustafa. *2nd ed.*

Author Profile



Mrs. Y. Sukanya received her B. Tech Degree in ECE Department from S.R.K.R Engineering College, Bheemavaram and obtained her M.Tech degree in Digital Electronics and Communication Systems from Gudlavalleru Engineering College. She has nine years of teaching experience, currently working at Vignan's Institute of Information Technology, Visakhapatnam as Associate Professor in Department of ECE. Her Area of interests are Communication systems and signal processing.



Mr .K. Lakshmana Rao has obtained B.Tech degree from Don Bosco institute of technology and sciences affiliated to JNTUK in the year 2012. Now he is pursuing M.Tech Degree in Department of Electronics & Communications, Vignan's institute of Information and Technology, Visakhapatnam. He is interested in the fields of Wireless Communication.