

Self Powered Sensor Based Environmental Bridge Condition Monitoring System Using Gsm

Prof.Dr.S.S.Patil, Bhadange Tejaswini, Jadhav Poonam, Jagtap Bhakti

Department of Electronics and Telecommunication Engineering,
Bharati Vidyapeeth's College of Engineering for Women,
University of Pune, Maharashtra, India

tejaswinibhadange141992@gmail.com, poonamjadhav54@gmail.com, bhakti32@gmail.com

Abstract- Basically, in this project we are going to monitor the parameters of the bridge which will help us to maintain the bridge and detect the faults in it. The real-time safety evaluation of bridges includes the following components: (1) real-time analysis of pressure (2) real-time analysis of temperature (3) real-time analysis of tilt (4) real-time analysis of weight (5) real-time analysis of flood (6) real-time boat detection. The sensors will detect the condition of the changing parameter of the bridge. The sensors installed on main cables, hangers, decks, towers, etc detect the strain, acceleration, temperature, wind and water level. The advancement in wireless technology has provided a motive to develop the wireless network based bridge health monitoring system. Sensor technologies have made the monitoring process more accurate and fast. GSM technology is suggested to send the data to the remote location in which the maintenance office is located. This project is useful for monitoring the faults and errors in the bridge and will help to prevent the loss of human life. It will also save the hazards which will create distractions in human life.

Keywords-ADXL335, GSM module, LM35, load cell, wind speed sensor.

I. INTRODUCTION

Structural Health Monitoring (SHM) concept is widely applied to various forms of infrastructures. Especially all over the world, countries enter into a greater period of construction of so many infrastructures. This range of infrastructures is bridged to skyscrapers. When damages to structures are concerned note that there are stages of increasing difficulty that require the knowledge of previous stages, that are: 1) Detecting the existence of the damage to the infrastructure 2) Locating the damage 3) Identifying the types of damage 4) Quantifying the severity of the damage. Basically, in our project we are going to monitor the parameters of the bridge which will help us to maintain the bridge and detect the faults in it. The sensors will detect the condition of the changing parameter of the bridge. Akashi Kaikyo Bridge is famous for the world longest suspension bridge, but famous also for its advanced health monitoring system. It has a technology called MBM (monitoring based maintenance) that enables the bridge Maintenance engineers monitor the condition of the bridge in real time. The sensors installed on main cables, hangers, decks, towers, etc. Detect the strain, acceleration, temperature, wind speed and water level. Sensor technologies have made the monitoring process more accurate and fast. The advancements of the sensor and sensor data processing technologies, there is one thing that has not been changed: data communication is

through wires and optical cables. In this project we used wireless technology to develop the wireless network based bridge health monitoring system. Wireless monitoring reduced maintenance costs and increase safety. Data collected by sensors will give a better understanding of the bridge dynamics and can be evaluated for bridge maintenance and repair purposes. GSM technology is suggested to send the data to the remote location in which the maintenance office is located.

II. BLOCK DIAGRAM

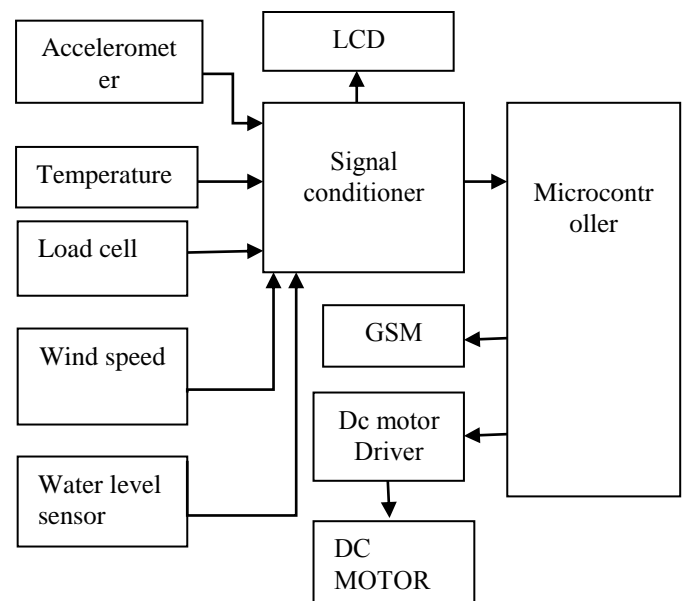

Figure 1: Block Diagram

III. BLOCK DIAGRAM DESCRIPTION

A. POWER SUPPLY

It is mainly used to provide DC voltage to the components on board. It supplies 12V for a DC motor, 5V for microcontroller and 5V for sensors.

B. SENSOR

1. ACCELEROMETER ADXL335

In this project accelerometer is used to measure the bridge tilt. We used ADXL335 accelerometer sensor. Accelerometer sensor can measure static (earth gravity) or dynamic acceleration in all three axes. Linear free fall detected by this sensor which has 0g output. Sensitivity can be in between two ranges. Acceleration is measured in unit meters per second. Gravitational acceleration produces by earth on all objects on earth. In all three axis one axes can measure the level of tilt of any platform. Accelerometer sensor data is sampled via an analog to digital converter which is fed into a microcontroller. Sensor data displayed on the LCD display and message send by the GSM module to the remote location where maintenance office is located. Accelerometer sensor is low range sensor accurate measure the tilt of a bridge. The ADXL335 is a small, thin, low power, complete 3-axis accelerometer with signal conditioned voltage outputs. The product measures acceleration with a minimum full-scale range of $\pm 3g$. The user selects the bandwidth of the accelerometer using the CX, CY, and CZ capacitors at the XOUT, YOUT, and ZOUT pins. Bandwidths can be selected to suit the application, with a range of 0.5 Hz to 1600 Hz for the X and Y axes, and a range of 0.5 Hz to 550 Hz for the Z axis.

2. LM35

LM35 sensor is used for accurate temperature measurement. LM35 sensor generates 10mv per degree Celsius. It is connected to the ADC of the microcontroller. The Vref of microcontroller will be adjusted to such value such that it will read 10mv=1count for example, if the ambient temperature is 25 deg the generated output will be 250 mV and after ADC the count will be 25. The LM35 series are precision integrated-circuit temperature Sensors. The output voltage of LM35 is linearly proportional to the Celsius (centigrade) temperature. To provide typical accuracies of $\pm 1/4^\circ\text{C}$ at room temperature and $\pm 3/4^\circ\text{C}$ over a full -55 to $+150^\circ\text{C}$ temperature range the LM35 does not require any external calibration and trimming. Low cost is assured by trimming and calibration. The LM35

have linear output, low output impedance and precise inherent calibration make interfacing to readout or control circuitry very easy. The LM35 is rated to operate over a -55° to $+150^\circ\text{C}$ temperature range, while the LM35c is rated for a -40° to $+110^\circ\text{C}$ range (-10° with improved accuracy). It has linear $+10\text{-mV}/^\circ\text{C}$ Scale Factor. It has Low Self-Heating, 0.08°C in Still Air.

3. LOAD CELL SENSOR

A load cell is in fact a resistance bridge. It is placed below the bridge to sense the weight of it. The LOAD cell will continuously give the weight readings in voltage format, which is then given to a signal conditioning unit which amplifies the voltage and is then give to the μc . The μc then converts the analog signal to digital format. A load cell is a transducer that is used to convert a force into an electrical signal. The output of the transducer can be scaled to calculate the force applied to the transducer.

4. WIND SPEED SENSOR

For wind speed measurement, we are using a 12v DC motor fan, which generates a voltage proportional to the speed in km/HR. We apply this voltage to the ADC of the microcontroller. Sensor data will display on the LCD display and message send by the GSM module to the remote location where the maintenance office is located.

5. IR PROXIMITY SENSOR

IR proximity sensor used for boat detection. Since the sensor module works on infrared. For obstacles with reflective surfaces that are white colored, the maximum range will be higher and for non-reflective surfaces that are black colored, the maximum range will be lower. Modes of operation 1. High level mode (ah mode) in this mode, if there is no obstacle then the output will be low (0v) & detecting an obstacle will change the output to high (5v) level. This mode can be enabled, if both the jumpers are connected to ah 2. Low level mode (al mode) in this mode, if there is no obstacle then the output will be high (5v) & detecting an obstacle will change the output to low (0v) level. This mode can be enabled, if both the jumpers are connected to al. If jumper is connected in any other way the output will be always high or low.

6. WATER LEVEL SENSOR

We are building our own water level sensor to detect the flood condition. The water level sensor is resistive type. As the water level increases the resistor level drops down. By using GSM

module message send to the remote location where maintenance office is located.

C. MICROCONTROLLER

It is used to process information that is being given by the sensors. It compares the received data with the threshold level set and accordingly output is generated. In this project we used PIC16F87XA-Pin Enhanced Flash Microcontroller. This μC have only 35 single word instructions to learn. This μC have up to 8K x 14 words of flash program memory, up to 368 x 8 bytes of data memory, up to 256 x 8 bytes of EEPROM data memory and also 10-bit, up to 8-channel Analog -to-Digital Converter (A/D). The Operating voltage range of this μC is 2.0V to 5.5V.

D. GSM MODULE

It is used to send message to the maintenance office if the bridge parameters exceed the set threshold levels. We can send short text messages to the required authorities as per the application with the help of GSM module interfaced. GSM module is provided by SIM uses the mobile service provider and send SMS to the respective authorities as per programmed. It operates at either the 900 MHz or 1800 MHz frequency band. This GSM Modem can accept any GSM network operator SIM card and act just like a mobile phone with its own unique phone number. The main advantage of using this modem will be that you can use its RS232 port to develop and communicate embedded applications. The modem can be connected to PC serial port directly, or to any microcontroller. This GSM modem is a highly flexible plug and play quad band SIM900D GSM modem for direct and easy integration to RS232 applications.

E. DC MOTOR

DC Motors are used to physically drive the application as per the requirement provided in the software. To drive a DC motor, we need a DC motor driver called L293D. This DC motor driver is capable of driving 2 DC motors at a time.

F. LCD (LIQUID CRYSTAL DISPLAY)

The LCD is used in a project to visualize the output of the application. We have used 16x2 LCD which indicates 16 columns and 2 rows. So, we can write 16 characters in each line. So, total 32 characters we can display on 16x2 LCD. The LCD can also use in a project to check the output of different modules interfaced with the microcontroller. Thus LCD plays

a vital role in a project to see the output and to debug the system module wise in case of system failure in order to rectify the problem. An LCD is a small low cost display. It is easy to interface with a micro-controller because of an embedded controller. This controller is standard across many displays which mean many micro-controllers have libraries that make displaying messages as easy as a single line of code.

IV. CONCLUSION

We conclude that this project is useful for monitoring the faults and errors in the bridge and will help us to prevent the loss of human life. It will also save the hazards which will create distractions in human life. We can evaluate the sensor system and communication challenges in a real world setting. We can avoid accidents caused by the extreme weather condition.

REFERENCES

- [1] R. Brannstrom, D. Granlund" Sensor Monitoring of Bridge Movement: A System Architecture" *2012 5th IEEE Workshop On User Mobility and Vehicular Networks*
- [2] Mr. Andrew Lash (major: Electrical Engineering) &Mr. Andrew Stoffel (major: Electrical Engineering)" *2011 Wireless Monitoring of Bridges*"
- [3] Wendi Gao; Meina Song, "Design and Implement of SOA-based Bridge Monitoring System Data Layer," *e-Business Engineering (ICEBE), 2012 IEEE Ninth International Conference on, vol., no., pp.123, 127, 9-11 Sept. 2012*
- [4] Chung-Hsin Liu, Po-Cheng Teng "The Analysis for the Attack on the Wireless Bridge Monitoring System" *2010 Second International Conference on MultiMedia and Information Technology.*
- [5] Yu-Ting Liu and Jian-Hua Tong and Yiching Lin and Tsung-Han Lee and Chia-Feng Chang"Real-time Bridge Scouring Safety Monitoring System by Using Mobile Wireless Technology", *2010 Fourth International Conference on Genetic and Evolutionary Computing.*